

W-Verzahnung Lizenz Index-Werke  
*W-tooth system licence Index-Corporation*

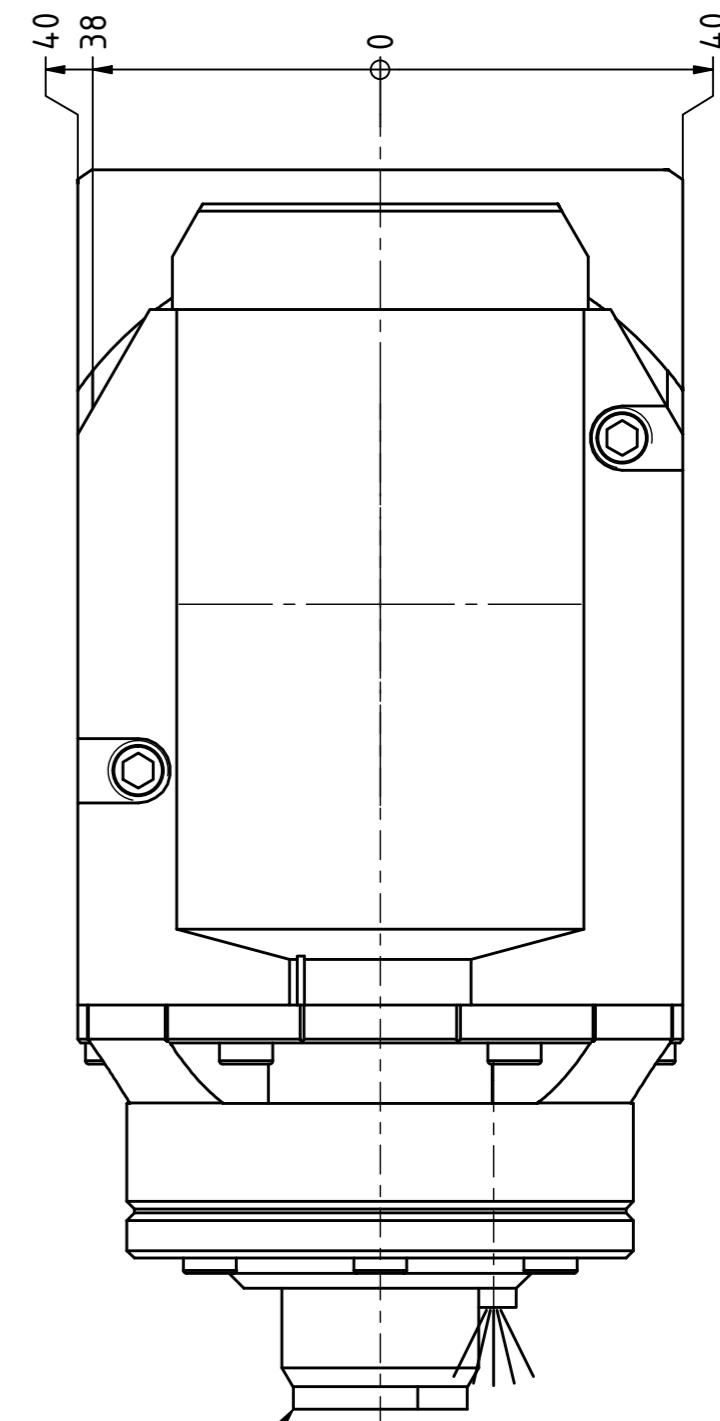

Formbore-Kopf MF1  
*Formbore-Head MF1*

Profil (Schlüsselweite) mm  
*Profile (spanner size) mm*

- Vierkant: SW4-14  
*square: SQ4-14*
- Sechskant: SW4-21  
*hexagon: SQ4-21*
- Kurvenblock ist im Werkzeug nicht enthalten!

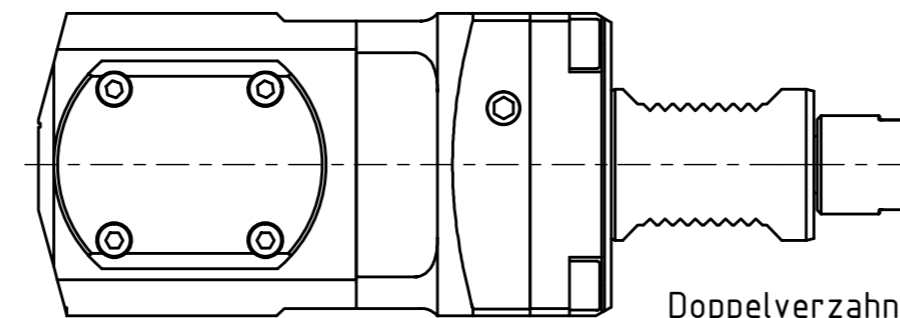

Doppelverzahnung Lizenz Traub  
*double tooth system licence Traub*

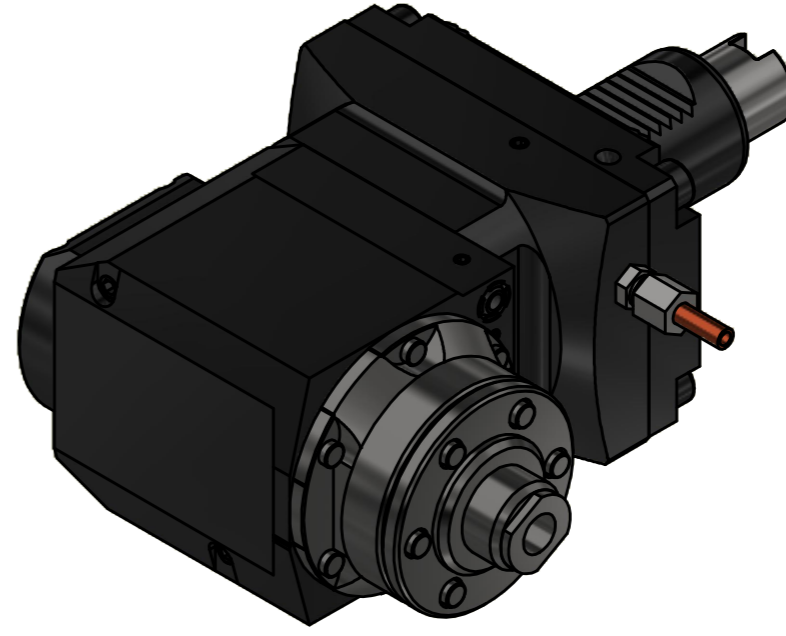

Copyright **EWS Tool Technologies**  
 Weitergabe und Vervielfältigung dieser Unterlage,  
 Verwertung und Mitteilung ihres Inhalts nicht  
 gestattet, soweit nicht ausdrücklich zugestanden.  
 Zuwiderhandlungen verpflichten zu Schadenersatz.

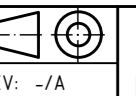
Bemerkung - Note	Technische Daten - technical data Weight = 8.864 [kg] Torque max. (M1/M2) = 5 / 5 [Nm] Speed max. (n1/n2) = 1000 / 1000 [1/min] Gear ratio (i)=n1:n2 = 1:1	Benennung - Title <b>Radial Bohr und Fräskopf</b> <i>Radial drilling and milling head</i>	 EWS Weigle GmbH & Co. KG Maybachstr. 1 D-73066 Uhingen www.ews-tools.de Technische Änderungen vorbehalten! <i>Subject to technical modifications!</i> IDENT: DEWS255251 Nr. - No. <b>60.40MF1G250RLWX110</b>	 MNR. <b>229521</b> REV: -/A
------------------	------------------------------------------------------------------------------------------------------------------------------------------------------------------------	-------------------------------------------------------------------------------------------------	----------------------------------------------------------------------------------------------------------------------------------------------------------------------------------------------------------------------------------------------------------------------------------------------------------------------------	-------------------------------------------------------------------------------------------------------------------------