

Doppelverzahnung Lizenz Traub
double tooth system licence Traub

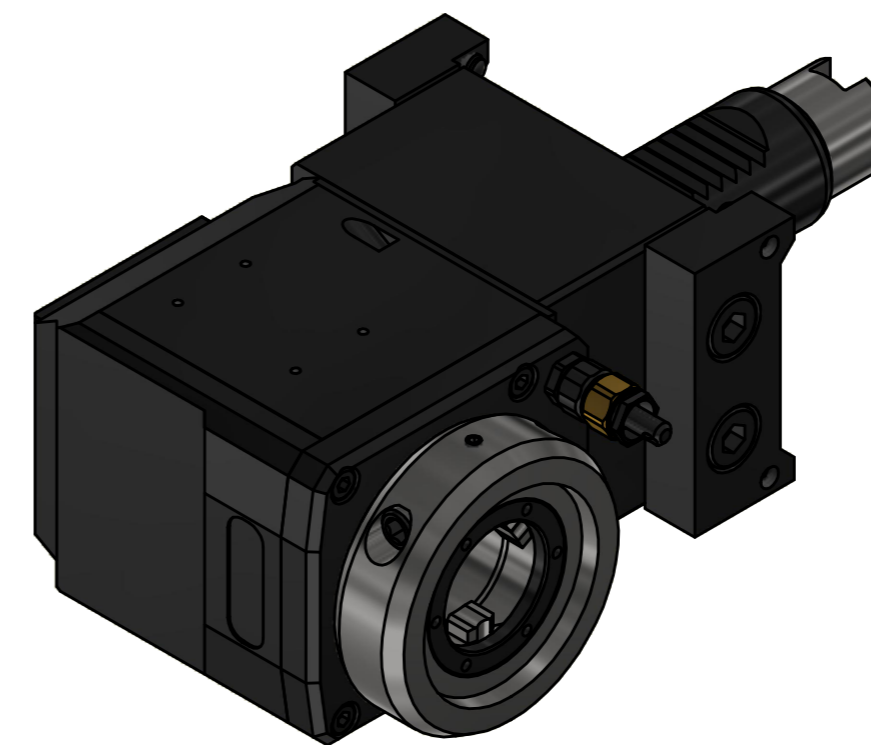
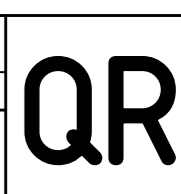

Copyright **EWS Tool Technologies**
Weitergabe und Vervielfältigung dieser Unterlage,
Verwertung und Mitteilung ihres Inhalts nicht
gestattet, soweit nicht ausdrücklich zugestanden.
Zu widerhandlungen verpflichten zu Schadenersatz.

<p>Bemerkung - Note</p> <p>mit Kegelrollenlager with taper roller bearing(s)</p>	<p>Technische Daten - technical data</p> <p>Weight = 4,856 [kg]</p> <p>Torque max. (M1/M2) = 20 / 40 [Nm]</p> <p>Speed max. (n1/n2) = 8000 / 4000 [1/min]</p> <p>Gear ratio (i)=n1:n2 = 2:1</p>	<p>Benennung - Title</p> <p>Radial Bohr und Fräskopf Radial drilling and milling head</p>	<p>EWS Tool Technologies EWS Weigle GmbH & Co. KG Maybachstr. 1 D-73066 Uhlingen www.ews-tool.de</p> <p>Technische Änderungen vorbehalten! Subject to technical modifications!</p> <p>IDENT: DEWS249458</p> <p>REV: -/A</p> <p>Nr. - No. 60.30VX3KRTNX65RLI2#01</p> <p>MNR. 229543</p>	 <p>QR</p>
--	---	---	---	---