

Spannzange / collet ER32 DIN6499  
Spannbereich / clamping range: 2,0 - 20,0

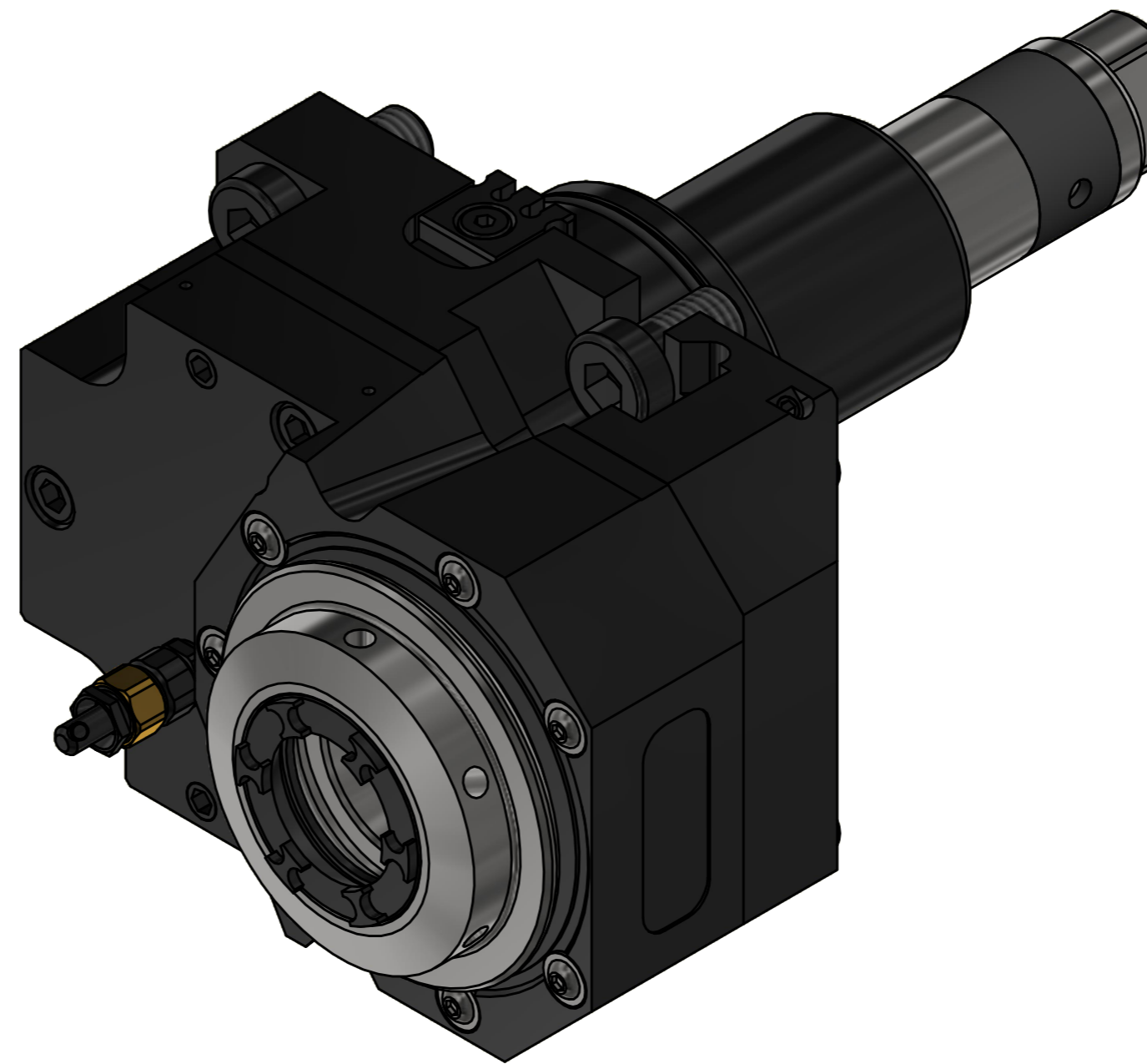

 Spannzangenschlüssel für innenliegende Mutter  
Clamping wrench for internal collet  
232AX

 Hakenschlüssel mit Zapfen  
Hook wrench with fixed pin  
DIN1810 B 58x62

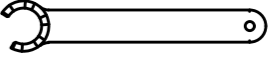
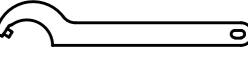
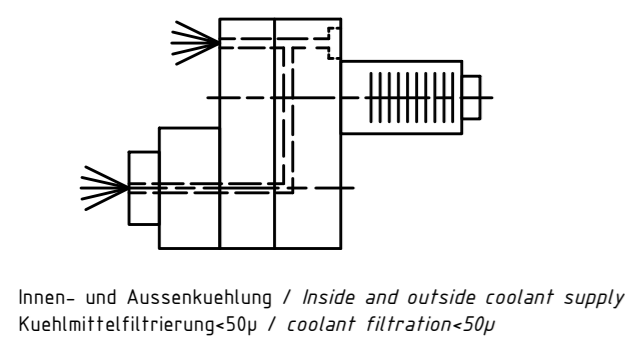

Benennung - Title	Technische Daten - technical data
Für Trockenlauf geeignet! Use without coolant fluid allowed!	Weight = 6.839 [kg] Torque max. (M1/M2) = 50 / 25 [Nm] Speed max. (n1/n2) = 6000 / 12000 [1/min] Gear ratio (i)=n1:n2 = 1:2 Pressure (pmax) = 70 [bar]

Benennung - Title	Technische Aenderungen vorbehalten! Subject to technical modifications!
	IDENT: DEWS246985 REV: -/A

EWS Tool Technologies	50.6532VT4FIKDI11M	229182
<small>EWS Weigle GmbH &amp; Co. KG Maybachstr. 1 D-73066 Uhlingen www.ews-tools.de</small>		

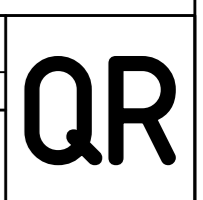

Copyright EWS Tool Technologies  
Weitergabe und Vervielfaeltigung dieser Unterlage,  
Verwertung und Mitteilung ihres Inhalts nicht  
gestattet, soweit nicht ausdrecklich zugestanden.  
Zuwerhandlungen verpflichten zu Schadenersatz.