

Spannzange / collet ER32 DIN6499
Spannbereich / clamping range: 2,0 - 20,0

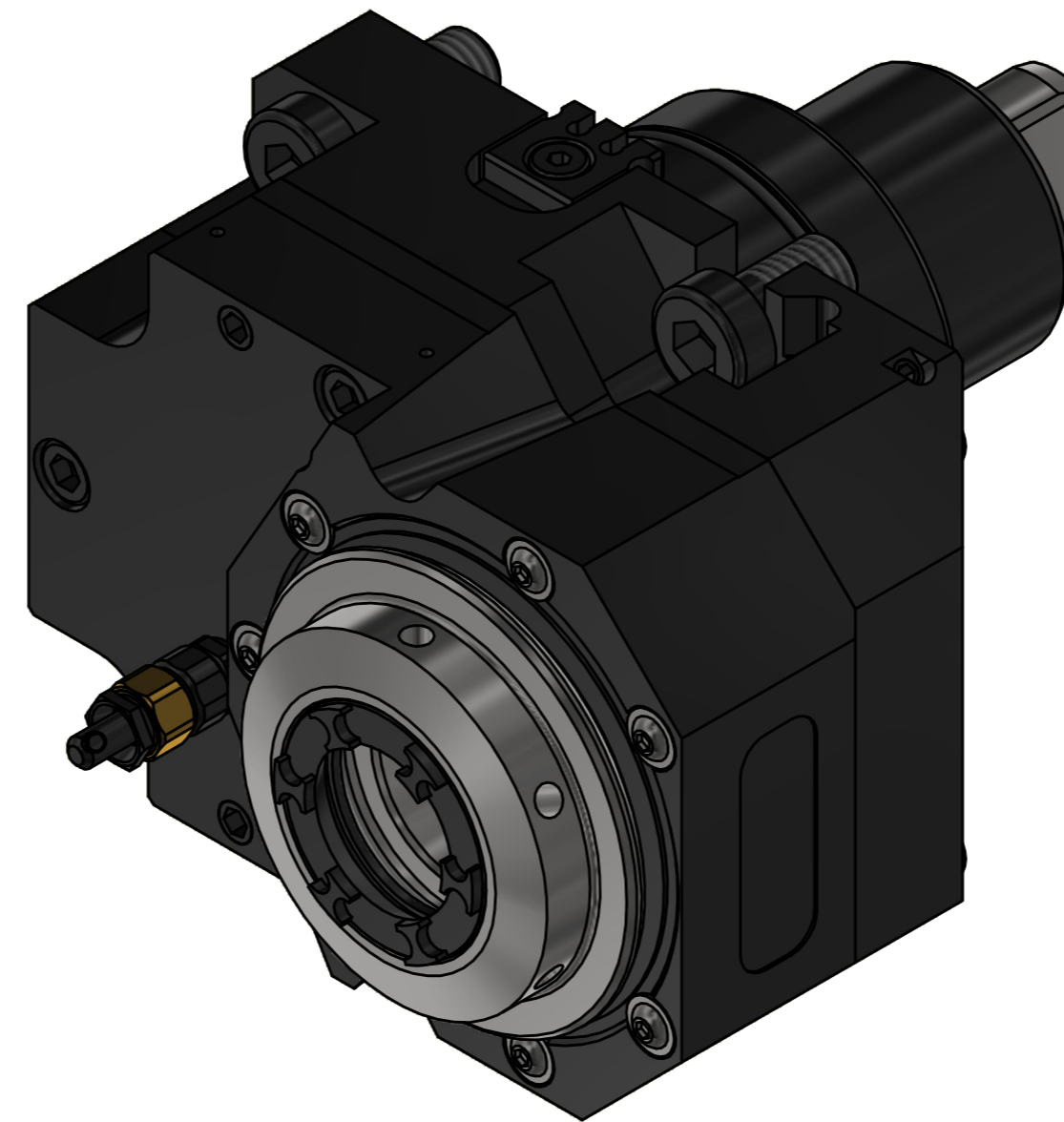

 Spannzangenschlüssel für innenliegende Mutter
Clamping wrench for internal collet
232AX

 Hakenschlüssel mit Zapfen
Hook wrench with fixed pin
DIN1810 B 58x62

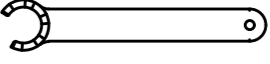
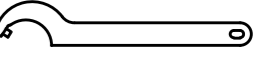
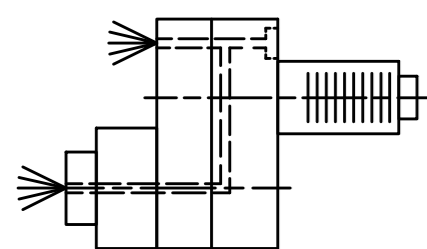

Innen- und Aussenkuehlung / Inside and outside coolant supply
Kuehlmittelfiltrierung-50µ / coolant filtration-50µ

Copyright **EWS Tool Technologies**
Weitergabe und Vervielfaeltigung dieser Unterlage,
Verwertung und Mitteilung ihres Inhalts nicht
gestattet, soweit nicht ausdrucklich zugestanden.
Zuwaerhandlungen verpflichten zu Schadenersatz.

<p>Bemerkung - Note Für Trockenlauf geeignet! Use without coolant fluid allowed!</p>	<p>Technische Daten - technical data Weight = 6.469 [kg] Torque max. (M1/M2) = 50 / 25 [Nm] Speed max. (n1/n2) = 6000 / 12000 [1/min] Gear ratio (i)=n1:n2 = 1:2 Pressure (pmax) = 70 [bar]</p>	<p>Benennung - Title Axial Bohr u. Fräskopf achsversetzt Ax. drill. and mill. head offset</p>	<p>EWS Tool Technologies EWS Weigle GmbH & Co. KG Maybachstr. 1 D-73066 Ulm/ingen www.ews-tools.de</p>	<p>Technische Aenderungen vorbehalten! Subject to technical modifications! IDENT: DEWS246800 REV: -/A</p>	<p>Nr. - No. 50.65321809MT110FIKDI11M</p> <p>MNR. 229170</p> <p>QR</p>
--	---	---	---	---	---