

Doppelverzahnung Lizenz Traub
 double tooth system licence Traub

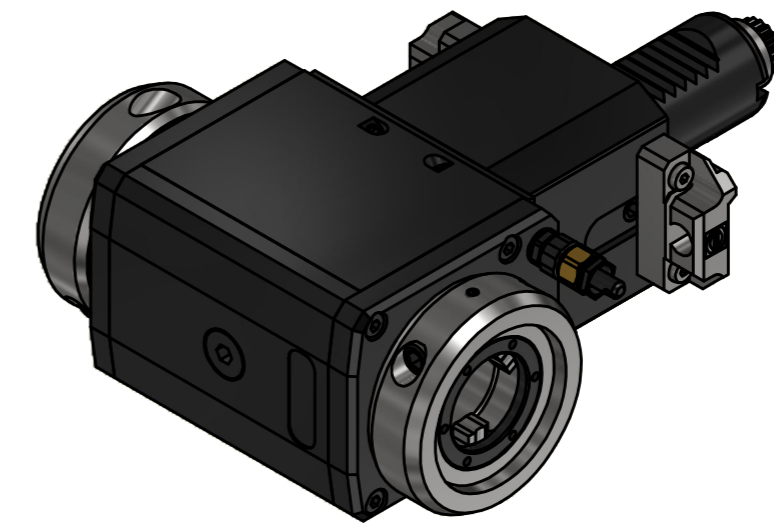

Copyright **EWS Tool Technologies**
 Weitergabe und Vervielfältigung dieser Unterlage,
 Verwertung und Mitteilung ihres Inhalts nicht
 gestattet, soweit nicht ausdrücklich zugestanden.
 Zuwiderhandlungen verpflichten zu Schadenersatz.

Bemerkung - Note	Technische Daten - technical data Weight = 5,715 [kg] Torque max. (M1/M2) = 32 / 32 32 [Nm] Speed max. (n1/n2) = 12000 / 12000 12000 [1/min] Gear ratio (i)=n1:n2 = 1:1 1:1	Benennung - Title Radial Bohr und Fräskopf Radial drilling and milling head	 EWS Weigle GmbH & Co. KG Maybachstr. 1 D-73066 Ulm/Ingen www.ews-tool.de Nr. - No. 60.30VX3LDCTXRLTFRHSD12	Technische Änderungen vorbehalten! Subject to technical modifications! IDENT: DEWS249144 REV: -/A MNR. 229479	 QR
------------------	---	---	--	---	---------------