

Spannzange / collet ER25 DIN6499
 Spannbereich / clamping range: 1,0 - 16,0

Schwenkbereich ±105°
 Swivel area ±105°

Gewindebohrzange / tapping collet
 ET-1-25 M3-M10

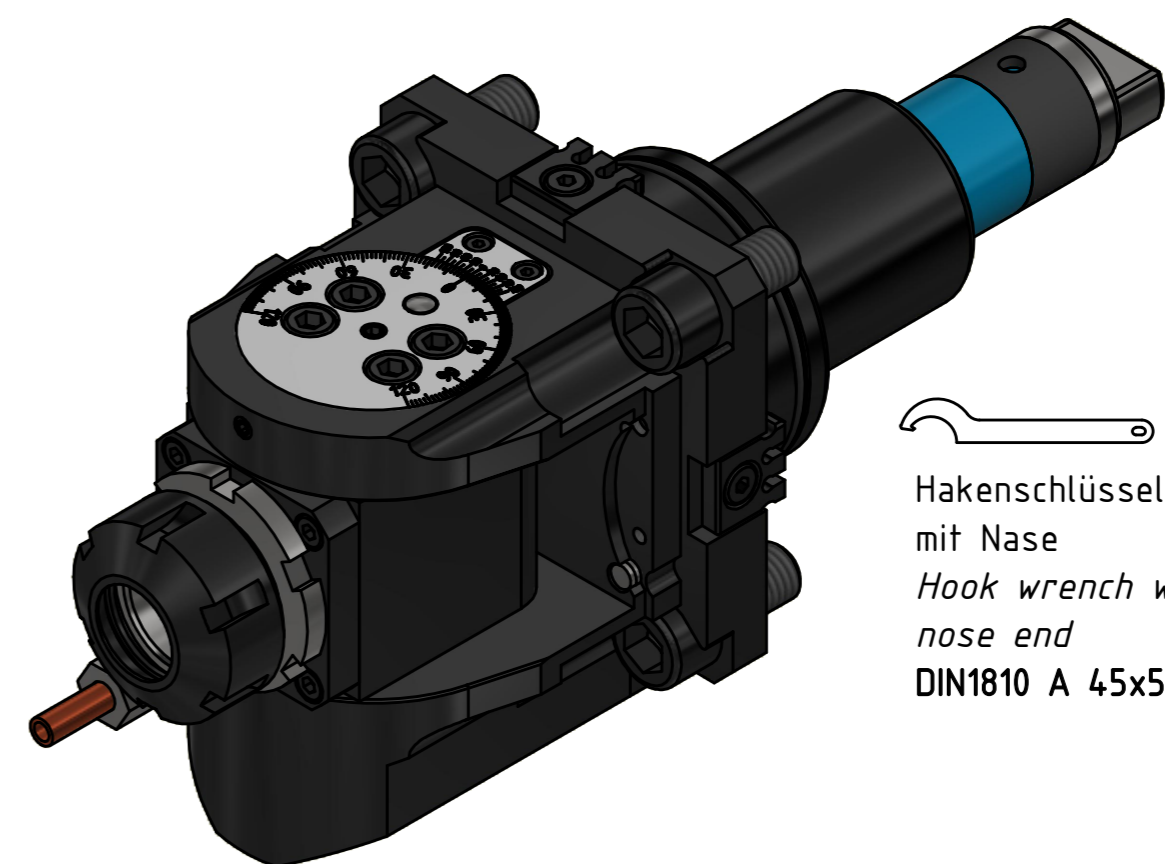
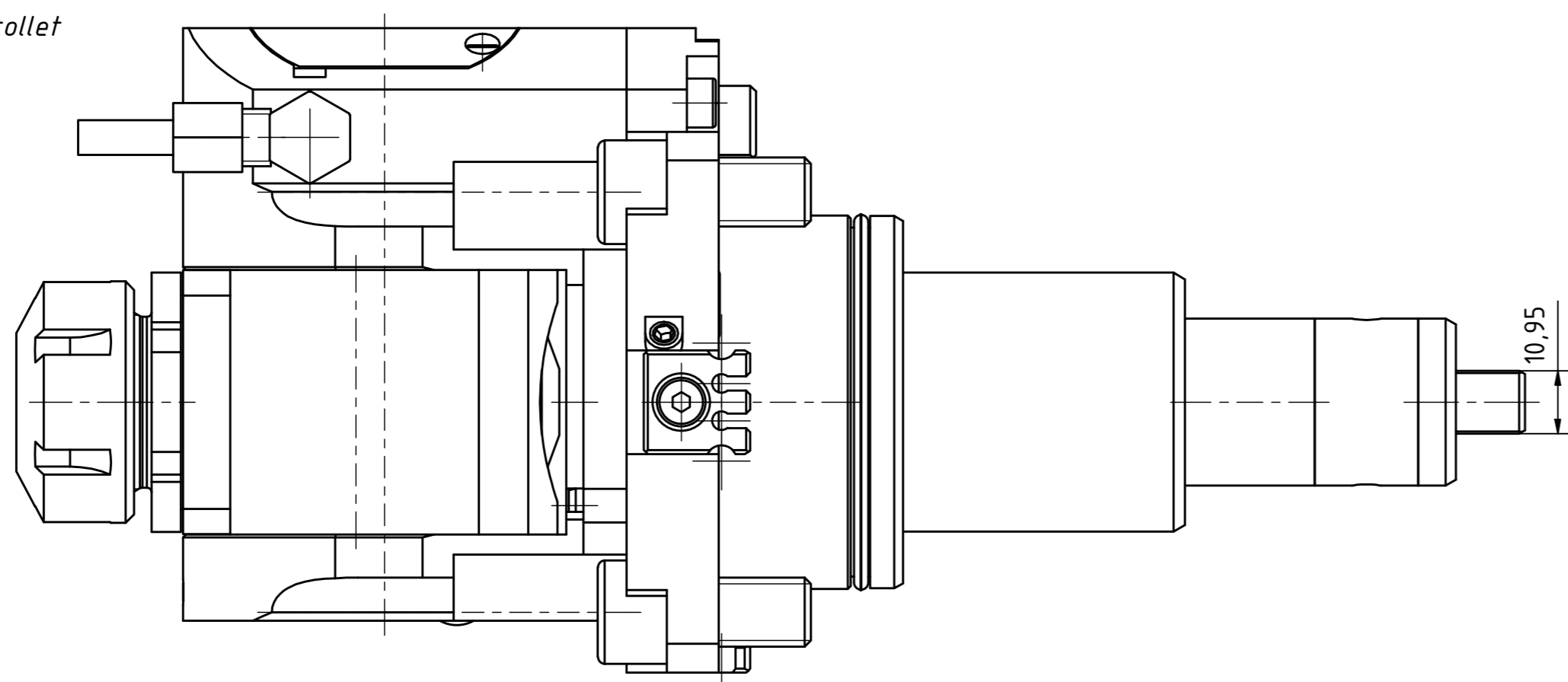

Hakenschlüssel
 mit Nase
 Hook wrench with
 nose end
 DIN1810 A 45x50

Spannzangenschlüssel
 Clamping wrench
 225

Bitte überprüfen Sie, ob der Werkzeughalter auf ihrem Revolver
 im Maschinenraum ohne Kollision durchschwenken kann.
 Please check the work space of the machine for interferences
 with the tool holder, especially the swiveling diameter.

Eine Nachbarstation könnte entfallen!
 A neighbouring station may be lost!

Copyright **EWS Tool Technologies**
 Weitergabe und Vervielfältigung dieser Unterlage,
 Verwertung und Mitteilung ihres Inhalts nicht
 gestattet, soweit nicht ausdrücklich zugestanden.
 Zuwiderhandlungen verpflichten zu Schadenersatz.

Bemerkung - Note	Technische Daten - technical data Weight = 5.460 [kg] Torque max. (M1/M2) = 20 / 20 [Nm] Speed max. (n1/n2) = 6000 / 6000 [1/min] Gear ratio (i)=n1:n2 = 1:1	Benennung - Title Schwenkkopf Swivel head	 EWS Weigle GmbH & Co. KG Maybachstr. 1 D-73066 Ulm/ingen www.ews-tools.de	Technische Änderungen vorbehalten! Subject to technical modifications! IDENT: DEWS247927 MNR.	 REV: -/B 229284
------------------	--	---	---	--	---

Nr. - No.
63.6525VT4F

229284

QR