

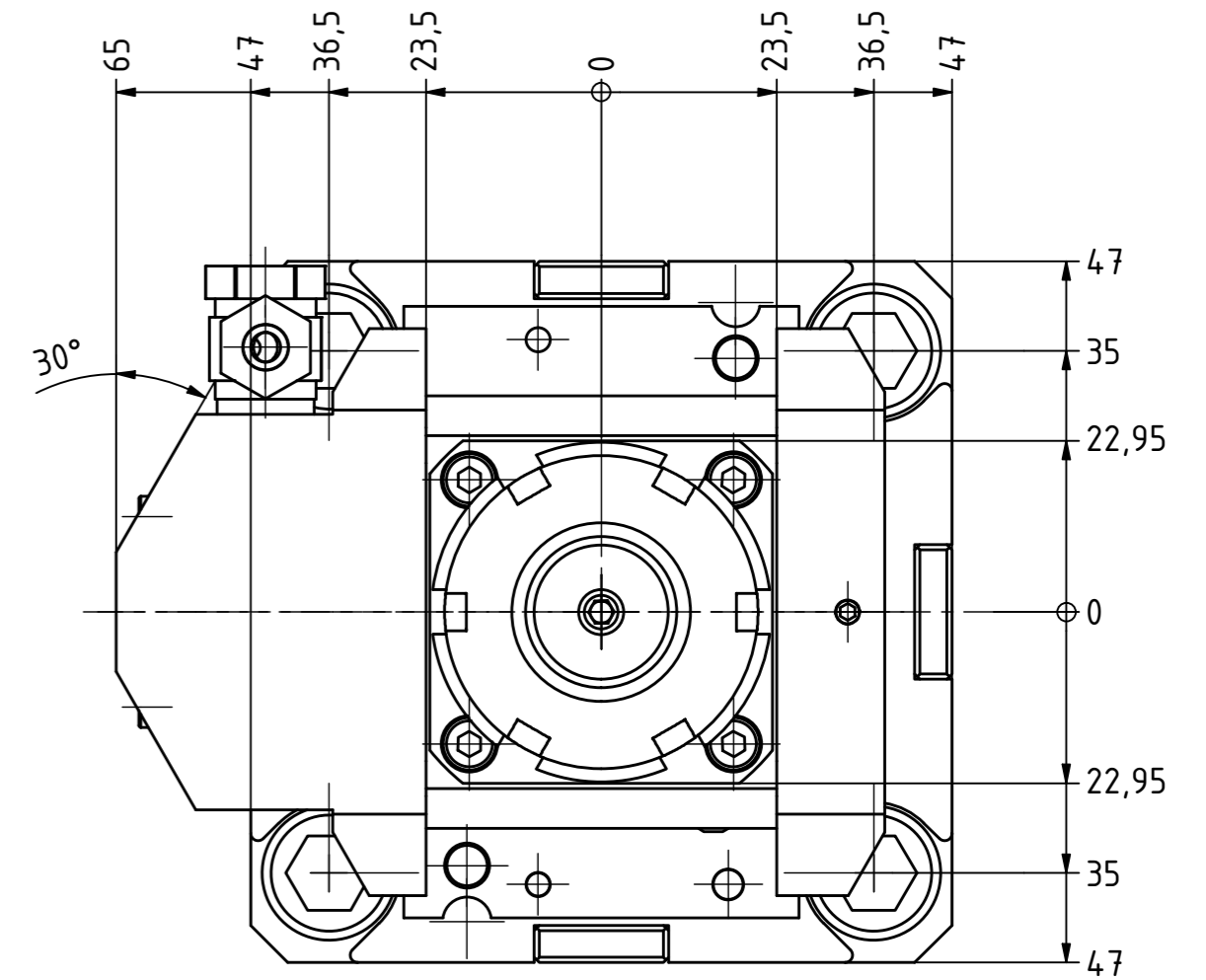

Ceramic Seal

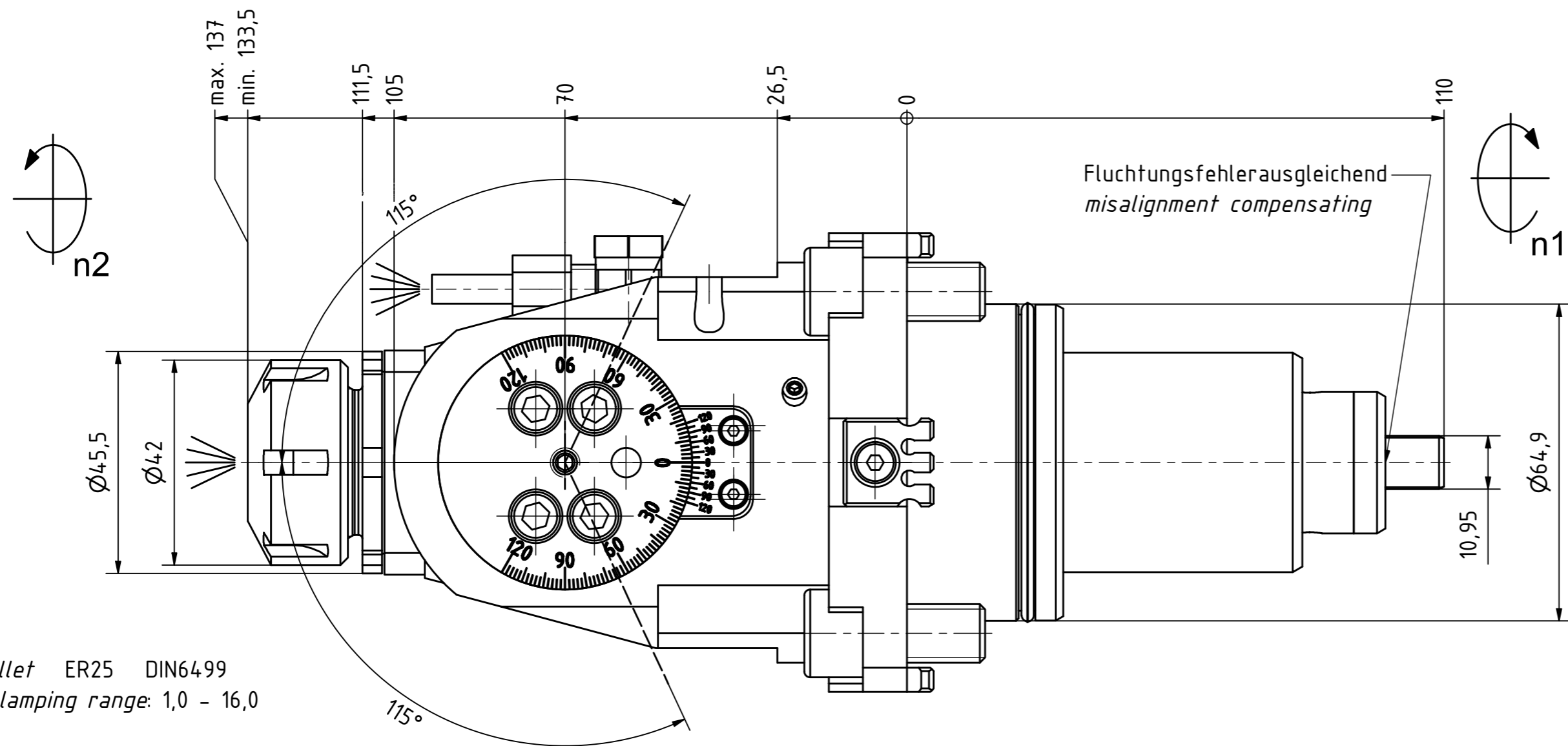

Tech Details



Spannzange / collet ER25 DIN6499
Spannbereich / clamping range: 1,0 - 16,0

Schwenkbereich ±115°
swivel area ±115°

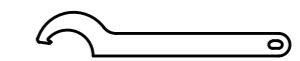
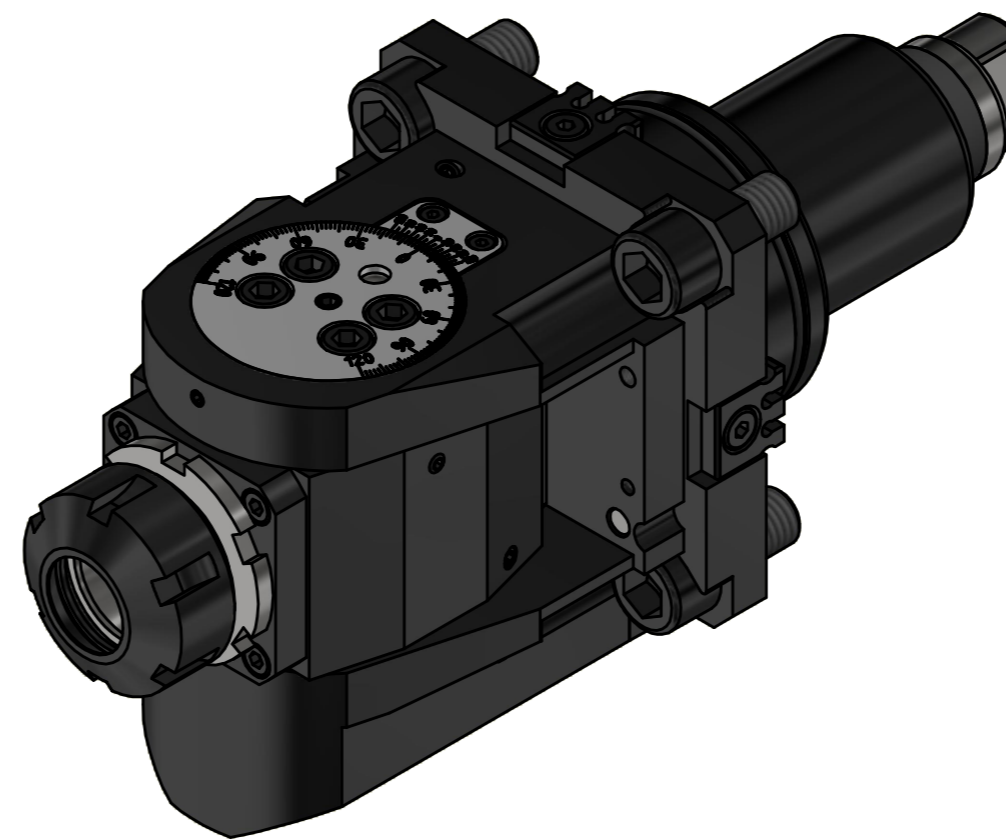

Hakenschlüssel
mit Nase
Hook wrench with
nose end
DIN1810 A 45x50

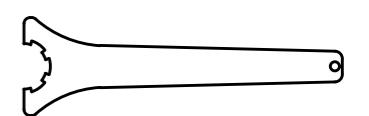

Spannzangenschlüssel
Clamping wrench
225

Bitte überprüfen Sie, ob der Werkzeughalter auf ihrem Revolver im Maschinenraum ohne Kollision durchschwenken kann.

Please check the work space of the machine for interferences with the tool holder, especially the swiveling diameter.

Eine Nachbarstation könnte entfallen!
one neighbouring position may be lost!

Copyright **EWS Tool Technologies**
Weitergabe und Vervielfältigung dieser Unterlage, Verwertung und Mitteilung ihres Inhalts nicht gestattet, soweit nicht ausdrücklich zugestanden. Zuwiderhandlungen verpflichten zu Schadenersatz.

<p>Bemerkung - Note Für Trockenlauf geeignet! Use without coolant fluid allowed!</p>	<p>Technische Daten - technical data Weight = 5,941 [kg] Torque max. (M1/M2) = 20 / 20 [Nm] Speed max. (n1/n2) = 6000 / 6000 [1/min] Gear ratio (i)=n1:n2 = 1:1 Pressure (pmax) = 70 [bar]</p>	<p>Benennung - Title Schwenkkopf Swivel head</p>	<p>EWS Tool Technologies EWS Weigle GmbH & Co. KG Maybachstr. 1 D-73066 Uhingen www.ews-tools.de</p>	<p>Technische Änderungen vorbehalten! Subject to technical modifications! IDENT: DEWS246133</p>	<p>REV: -/A MNR. 229279</p>
--	--	--	---	---	-------------------------------------

