

Spannzange / collet ER25 DIN6499
Spannbereich / clamping range: 1,0 - 16,0

Gewindebohrzange / tapping collet
ET-1-25 M3-M10

Schwenkbereich ±105°
Swivel area ±105°

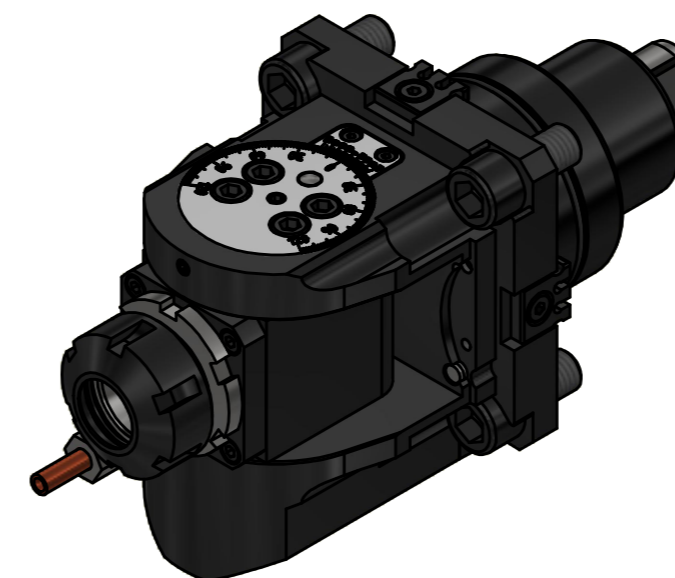
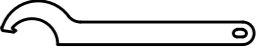

Hakenschlüssel
mit Nase
Hook wrench with
nose end
DIN1810 A 45x50

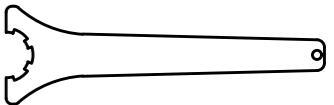

Spannzangenschlüssel
Clamping wrench
225

Bitte überprüfen Sie, ob der Werkzeughalter auf ihrem Revolver
im Maschinenraum ohne Kollision durchschwenken kann.

Please check the work space of the machine for interferences
with the tool holder, especially the swiveling diameter.

Eine Nachbarstation könnte entfallen!
A neighbouring station may be lost!

Copyright **EWS Tool Technologies**
Weitergabe und Vervielfältigung dieser Unterlage,
Verwertung und Mitteilung ihres Inhalts nicht
gestattet, soweit nicht ausdrücklich zugestanden.
Zuwerhandlungen verpflichten zu Schadenersatz.

Bemerkung - Note	Technische Daten - technical data Weight = 5.090 [kg] Torque max. (M1/M2) = 20 / 20 [Nm] Speed max. (n1/n2) = 6000 / 6000 [1/min] Gear ratio (i)=n1:n2 = 1:1	Benennung - Title Schwenkkopf Swivel head	 EWS Weigle GmbH & Co. KG Maybachstr. 1 D-73066 Uhlingen www.ews-tools.de Technische Änderungen vorbehalten! Subject to technical modifications! IDENT: DEWS248166 Nr. - No. 63.65251809MT110F	 MNR. 229278
------------------	--	---	--	--