

Trifix Anzugsdrehmoment 25 Nm
Trifix clamping torque 25 Nm

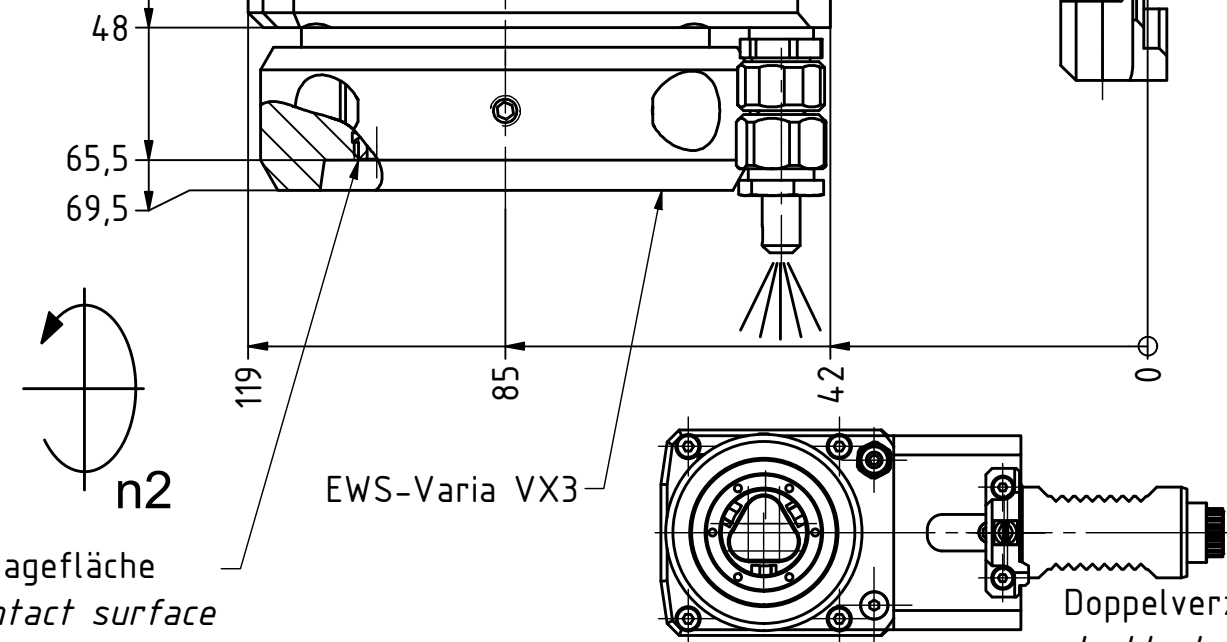

Doppelverzahnung Lizenz Traub
double tooth system licence Traub

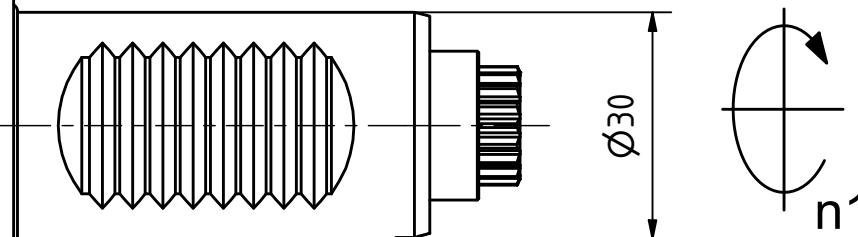
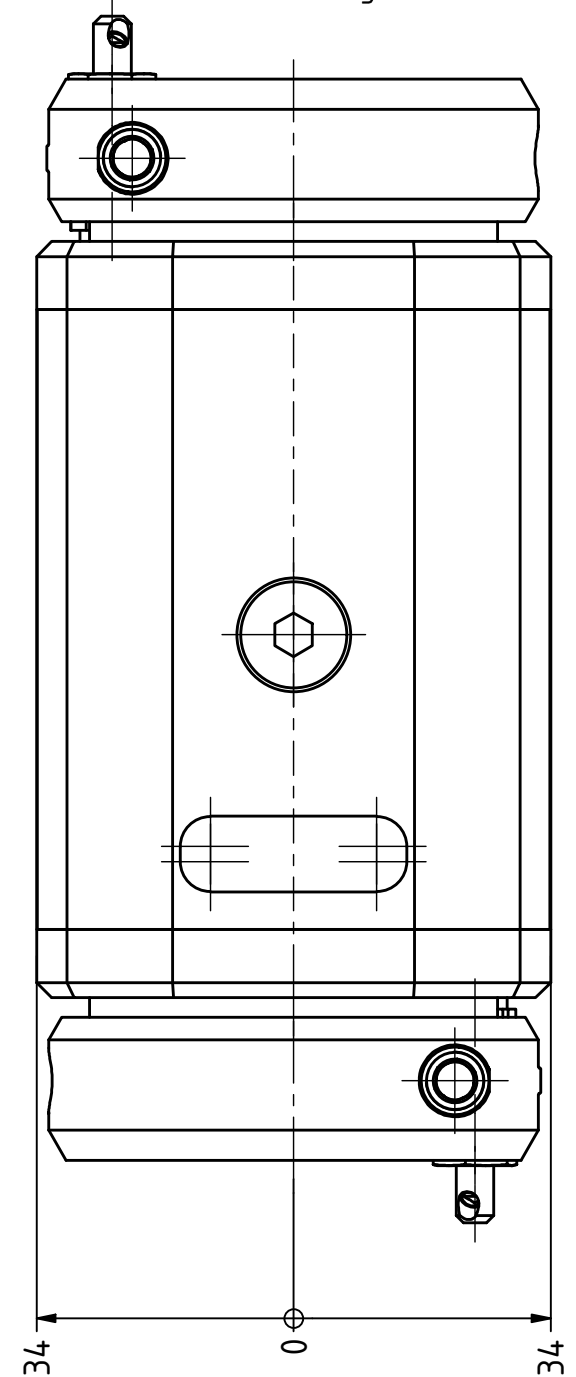
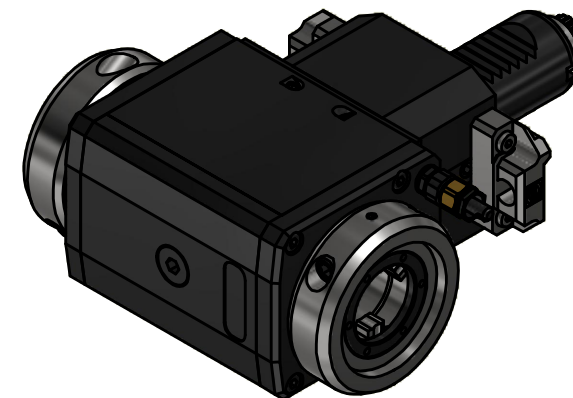

Copyright **EWS Tool Technologies**
Weitergabe und Vervielfaeltigung dieser Unterlage,
Verwertung und Mitteilung ihres Inhalts nicht
gestattet, soweit nicht ausdrecklich zugestanden.
Zuwiderhandlungen verpflichten zu Schadenersatz.

Bemerkung - Note

Technische Daten - technical data

Weight = 5.310 [kg]
Torque max. (M1/M2) = 32 / 32 [Nm]
Speed max. (n1/n2) = 12000 / 12000 | 12000 [1/min]
Gear ratio (i)=n1:n2 = 1:1 | 1:1

Benennung - Title

Radial Bohr und Fräskopf
Radial drilling and milling head

EWS
Tool Technologies

EWS Weigle GmbH & Co. KG
Maybachstr. 1
D-73066 Uthingen
www.ews-tools.de

Technische Aenderungen vorbehalten!
Subject to technical modifications!

IDENT: DEWS248512



REV: -/A

Nr. - No.

60.30VX3DGT300RLTFRHSD12

MNR.

229401

QR