

Doppelverzahnung Lizenz Traub
double tooth system licence Traub

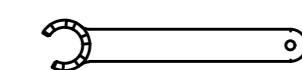

Spannzangenschlüssel für
innenliegende Mutter
Clamping wrench for
internal collet
225AX

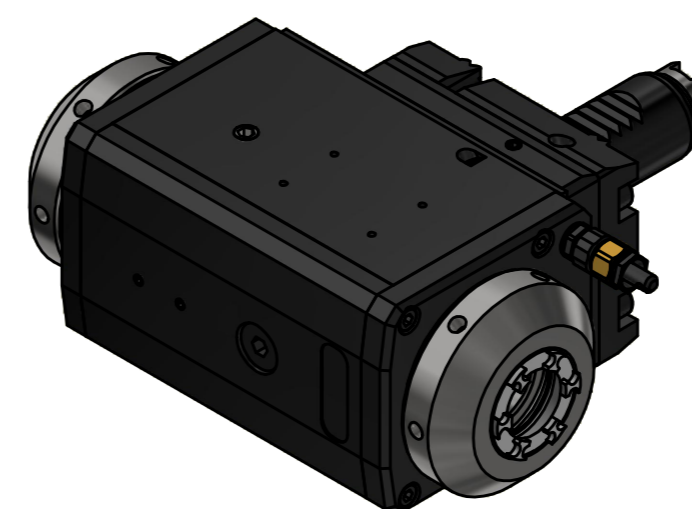
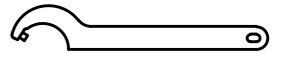

Hakenschlüssel
mit Zapfen
Hook wrench
with fixed pin
DIN1810 B 58x62
225AX

Copyright **EWS Tool Technologies**
Weitergabe und Vervielfältigung dieser Unterlage,
Verwertung und Mitteilung ihres Inhalts nicht
gestattet, soweit nicht ausdrücklich zugestanden.
Zuwerhandlungen verpflichten zu Schadenersatz.

Benennung - Title	Technische Daten - technical data
	Weight = 5,904 [kg]
	Torque max. (M1/M2) = 25 / 25 25 [Nm]
	Speed max. (n1/n2) = 8000 / 8000 8000 [1/min]
	Gear ratio (i)=n1:n2 = 1:1 1:1

Benennung - Title
Radial Bohr und Fräskopf
Radial drilling and milling head

EWS Tool Technologies	EWS Weigle GmbH & Co. KG Maybachstr. 1 D-73066 Ulm/ingen www.ews-tool.de	Technische Änderungen vorbehalten! Subject to technical modifications!	REV: -/A
	Nr. - No. 60.2525DG200RLEKWIM-S01	IDENT: DEWS248198	

