

Spannzange / collet ER32 DIN6499  
Spannbereich / clamping range: 2,0 - 20,0

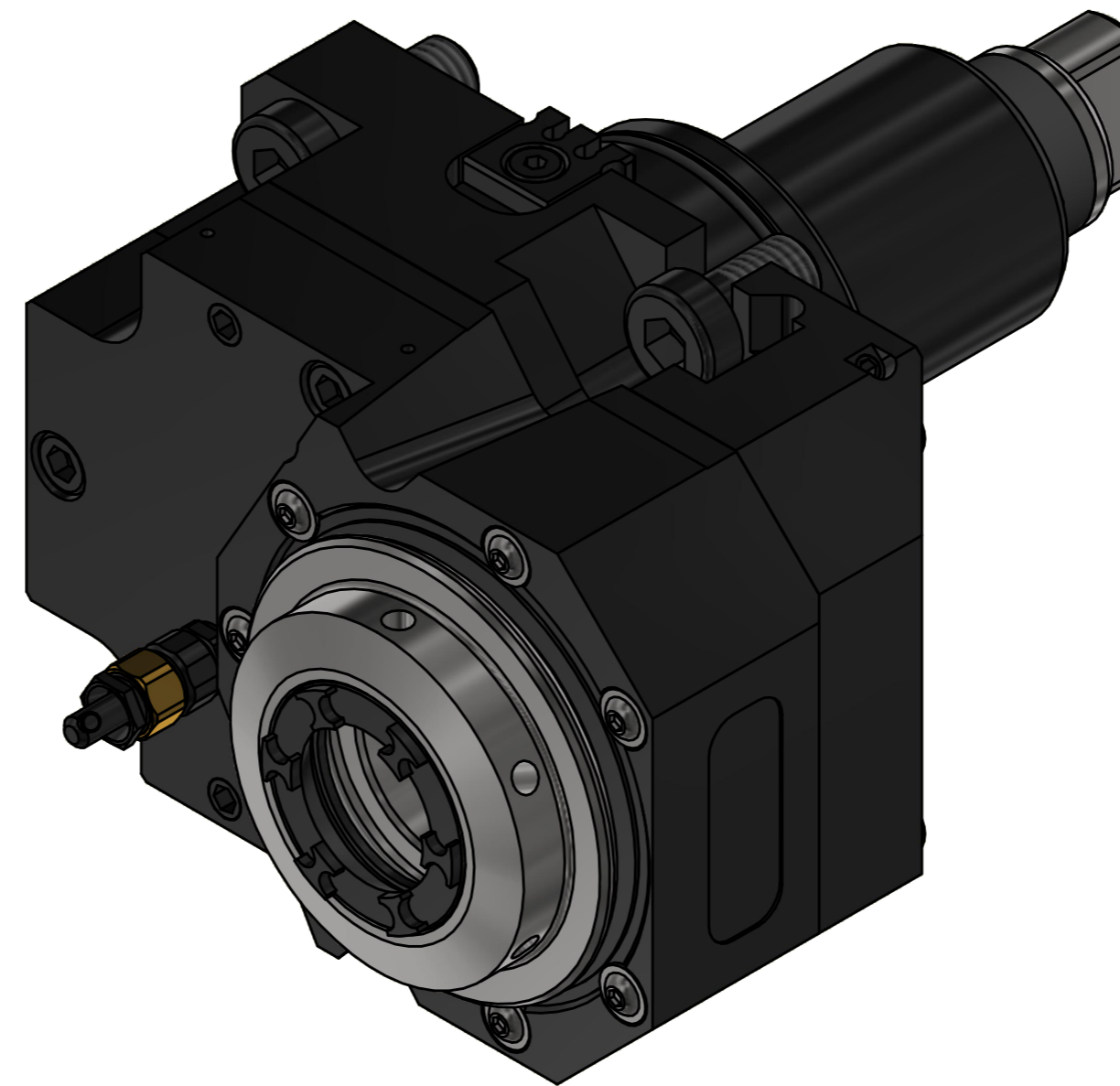

Spannzangenschlüssel für innenliegende Mutter  
Clamping wrench for internal collet  
232AX

Hakenschlüssel mit Zapfen  
Hook wrench with fixed pin  
DIN1810 B 58x62

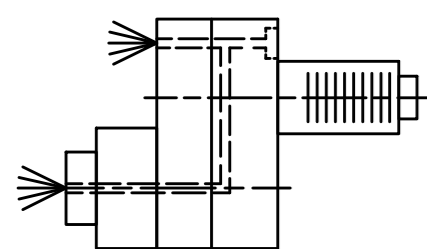

Innen- und Aussenkuehlung / Inside and outside coolant supply  
Kuehlmittelfiltrierung-50µ / coolant filtration-50µ

<p>Bemerkung - Note Für Trockenlauf geeignet! Use without coolant fluid allowed!</p>	<p>Technische Daten - technical data Weight = 6.685 [kg] Torque max. (M1/M2) = 50 / 25 [Nm] Speed max. (n1/n2) = 6000 / 12000 [1/min] Gear ratio (i)=n1:n2 = 1:2 Pressure (pmax) = 70 [bar]</p>	<p>Benennung - Title <b>Axial Bohr u. Fräskopf achsversetzt</b> <b>Ax. drill. and mill. head offset</b></p>	<p><b>EWS</b> Tool Technologies EWS Weigle GmbH &amp; Co. KG Maybachstr. 1 D-73066 Uhingen www.ews-tools.de</p> <p>Technische Aenderungen vorbehalten! Subject to technical modifications! IDENT: DEWS246776 REV: -/A MNR. 229166</p>	<p><b>QR</b></p>
--	---	---	---	------------------

Copyright **EWS Tool Technologies**  
Weitergabe und Vervielfaeltigung dieser Unterlage,  
Verwertung und Mitteilung ihres Inhalts nicht  
gestattet, soweit nicht ausdrecklich zugestanden.  
Zuwoerhandlungen verpflichten zu Schadenersatz.