

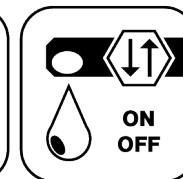

Butterfly Seal



Coolant Management



Tech Details

Fluchtungsfehlerausgleichend  
misalignment compensating

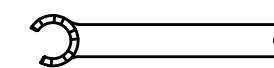
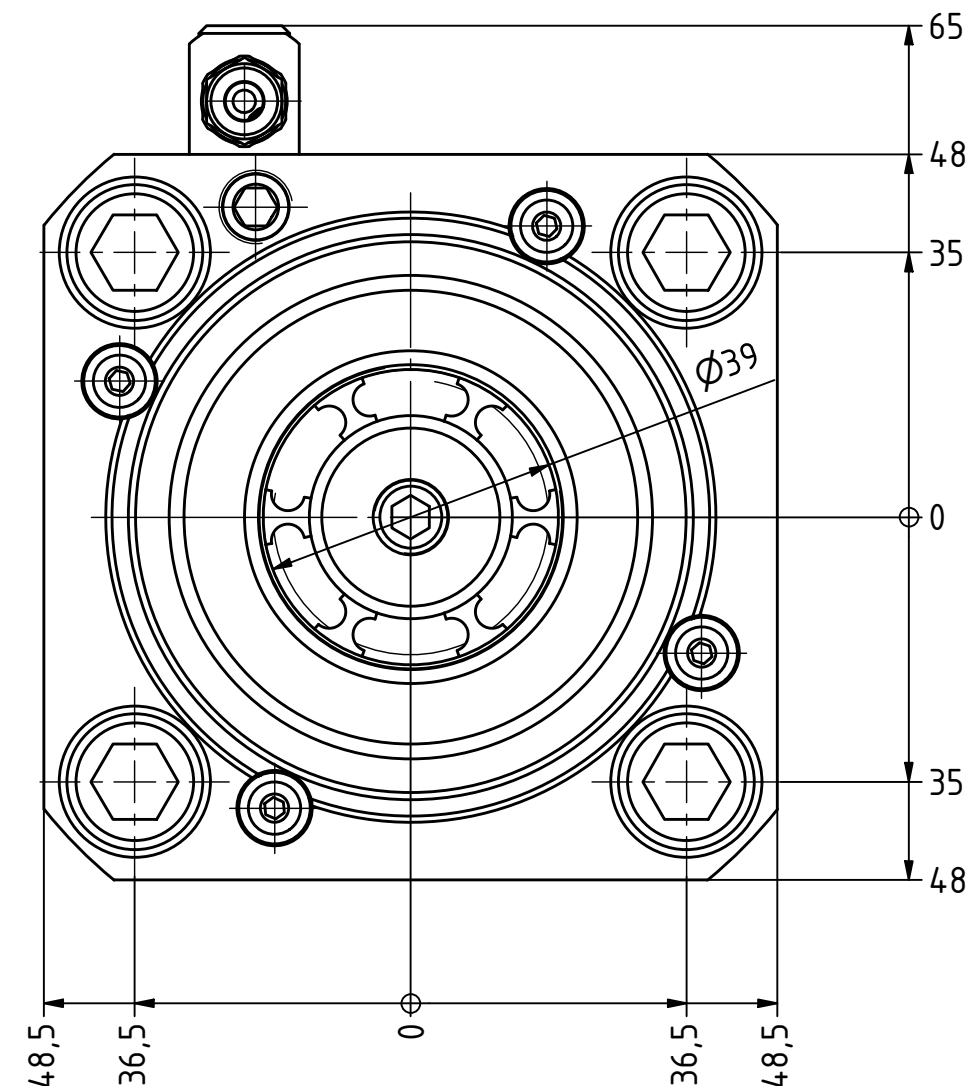
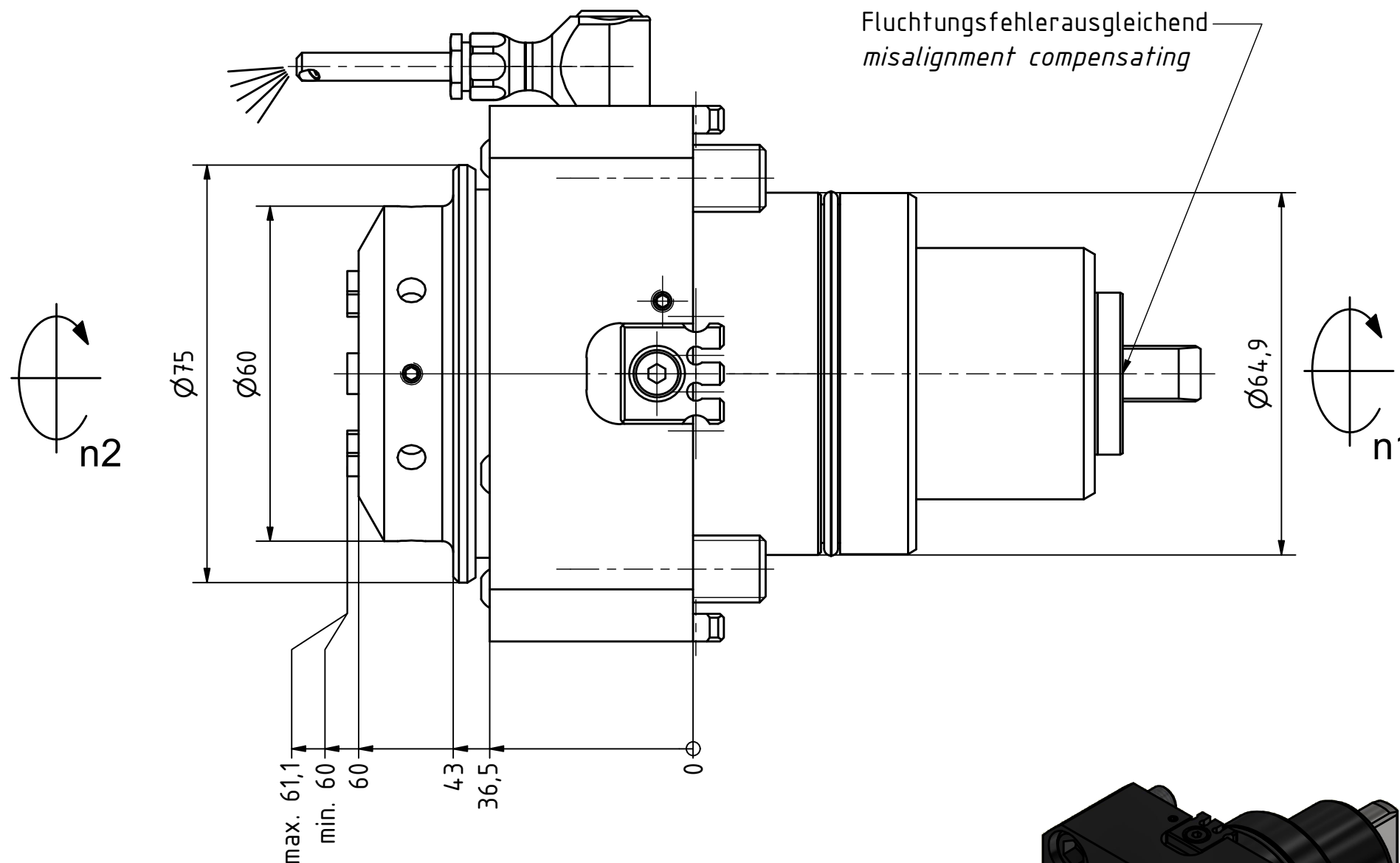

Spannzangenschlüssel für  
innenliegende Mutter  
Clamping wrench for  
internal collet  
232AX

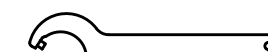

Hakenschlüssel  
mit Zapfen  
Hook wrench  
with fixed pin  
DIN1810 B 58x62

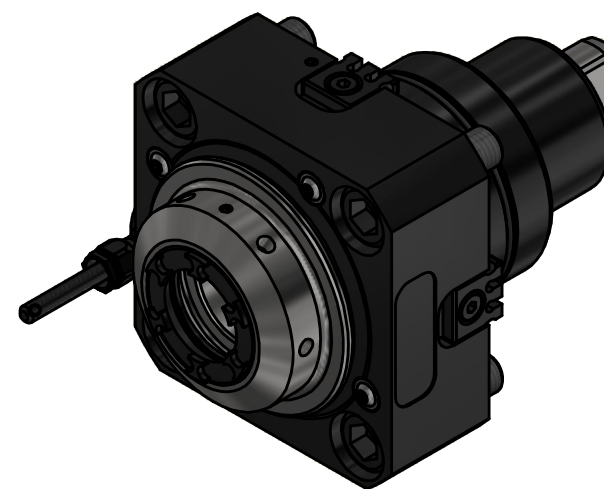

Spannzange / collet ER32 DIN6499  
Spannbereich / clamping range: 2,0 - 20,0

Gewindebohrzange / tapping collet  
ET-1-32 M5-M12

Copyright **EWS Tool Technologies**  
Weitergabe und Vervielfaeltigung dieser Unterlage,  
Verwertung und Mitteilung ihres Inhalts nicht  
gestattet, soweit nicht ausdrecklich zugestanden.  
Zuwiderhandlungen verpflichten zu Schadenersatz.

Bemerkung - Note

mit Kegelrollenlager  
with taper roller bearing(s)

Technische Daten - technical data

Weight = 3.919 [kg]  
Torque max. (M1/M2) = 80 / 80 [Nm]  
Speed max. (n1/n2) = 5000 / 5000 [1/min]  
Gear ratio (i)=n1:n2 = 1:1

Benennung - Title

**Axial Bohr und Fräskopf**  
**Axial drilling and milling head**



EWS Weigele GmbH & Co. KG  
Maybachstr. 1  
D-73066 UHINGEN  
www.ews-tools.de

Technische Aenderungen vorbehalten!  
Subject to technical modifications!

IDENT: DEWS243896



REV: -/A

Nr. - No.

40.6532KR1809MT110FIM

MNR.

229093

