

Spannzange / collet ER32 DIN6499
 Spannbereich / clamping range: 2,0 - 20,0

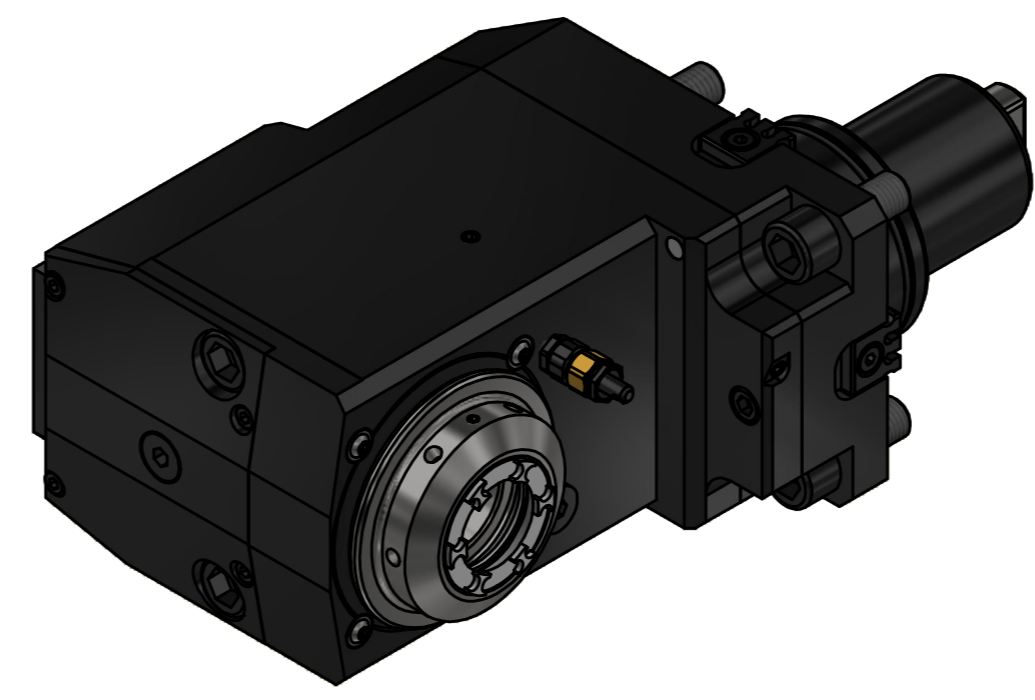

Spannzangenschlüssel für innenliegende Mutter
 Clamping wrench for internal collet
 232AX

Hakenschlüssel mit Zapfen
 Hook wrench with fixed pin
 DIN1810 B 58x62

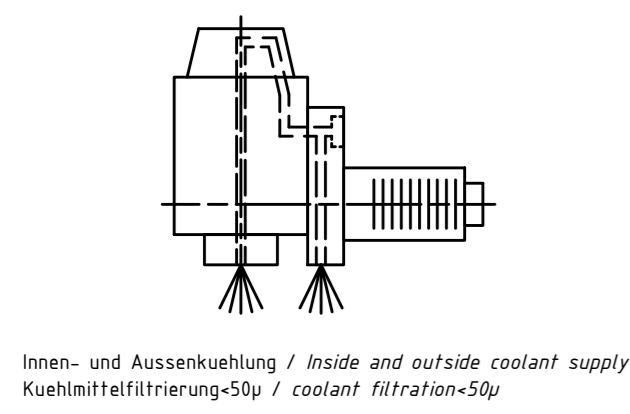

Copyright **EWS Tool Technologies**
 Weitergabe und Vervielfaeltigung dieser Unterlage, Verwertung und Mitteilung ihres Inhalts nicht gestattet, soweit nicht ausdrecklich zugestanden. Zuwiderhandlungen verpflichten zu Schadenersatz.

| | | | | | |
|--|--|--|---|---|------------------|
| <p>Bemerkung - Note Für Trockenlauf geeignet! Use without coolant fluid allowed! mit Kegelrollenlager with taper roller bearing(s)</p> | <p>Technische Daten - technical data Weight = 12.802 [kg] Torque max. (M1/M2) = 80 / 80 [Nm] Speed max. (n1/n2) = 5000 / 5000 [1/min] Gear ratio (i)=n1:n2 = 1:1 Pressure (pmax) = 70 [bar]</p> | <p>Benennung - Title Radial Bohr und Fräskopf, zurückges Radial drill. and mill. head offset</p> | <p>EWS Tool Technologies EWS Weigle GmbH & Co. KG Maybachstr. 1 D-73066 Uhlingen www.ews-tool.de</p> | <p>Technische Aenderungen vorbehalten! Subject to technical modifications! IDENT: DEWS243351 REV: -/A MNR. 229107</p> | <p>QR</p> |
|--|--|--|---|---|------------------|