

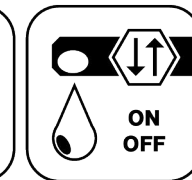

Butterfly Seal



Coolant Management



Tech Details

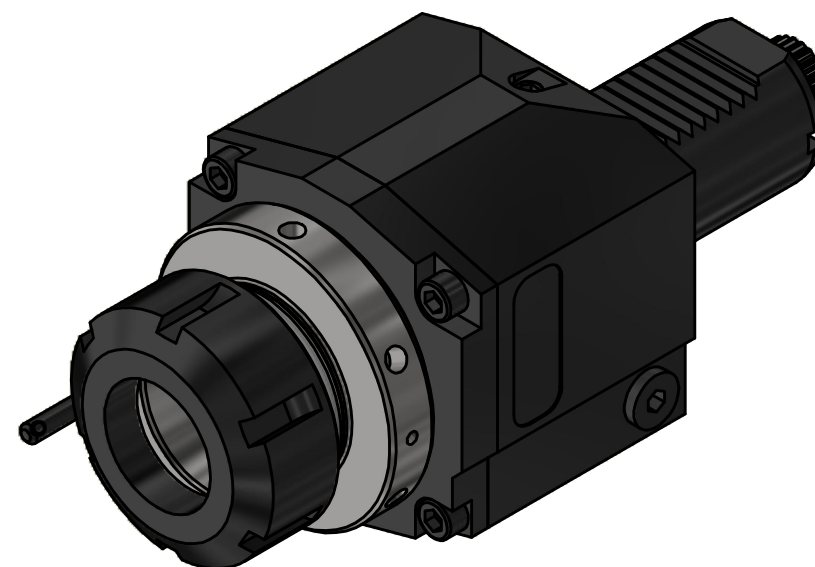
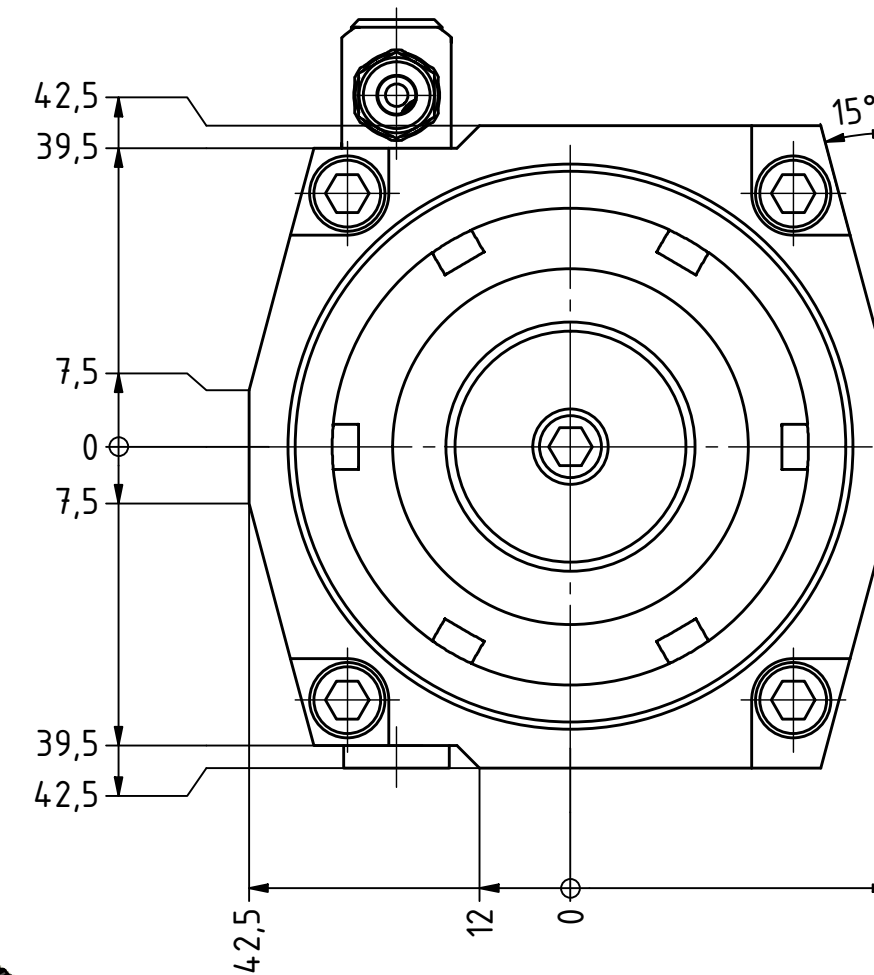
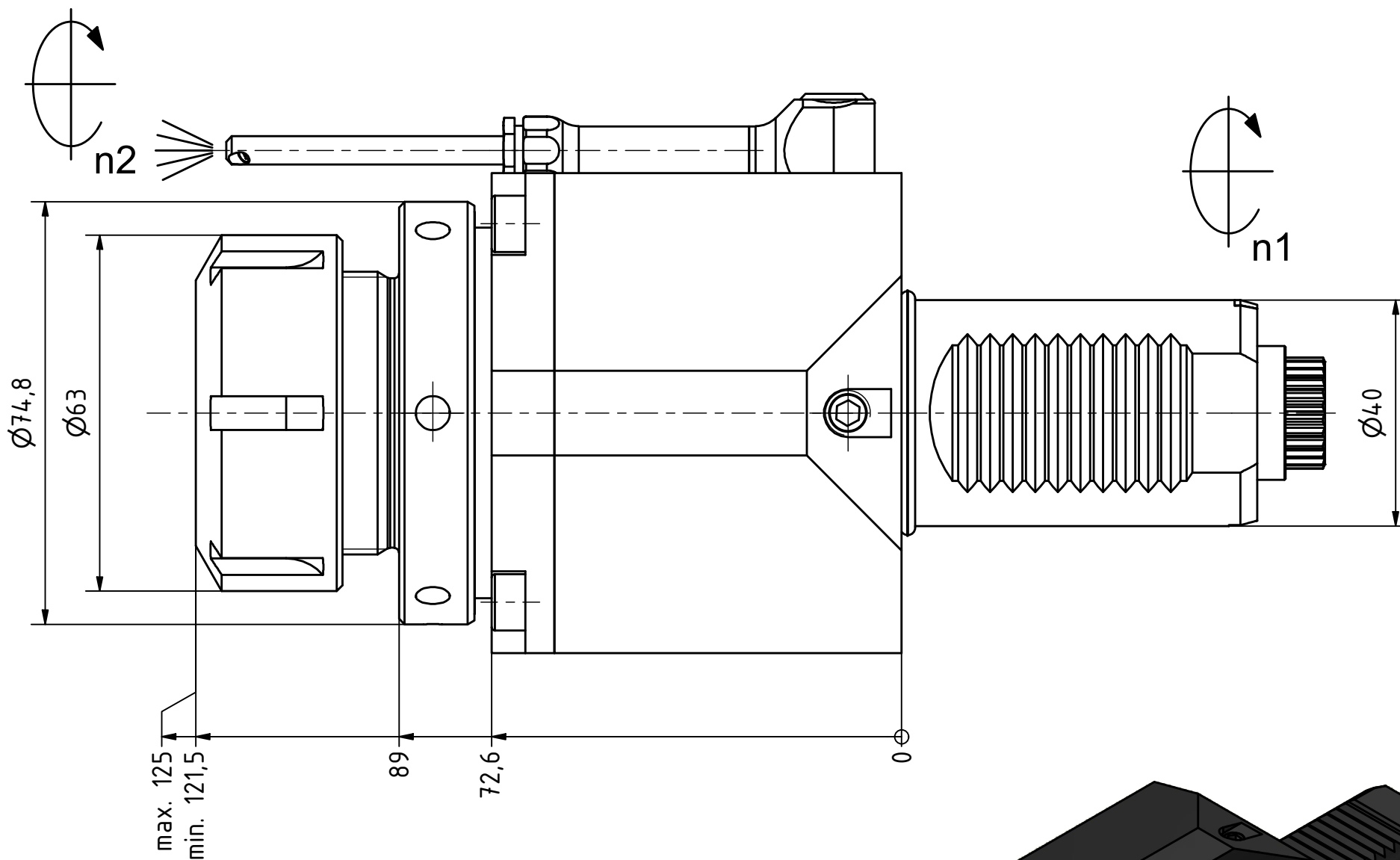

Spannzange / collet ER40 DIN6499  
 Spannbereich / clamping range: 3,0 - 26,0

Gewindebohrzange / tapping collet  
 ET-1-40 M6-M16

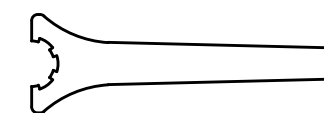

Spannzangenschlüssel  
 Clamping wrench  
 240

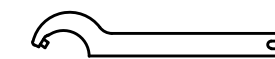

Hakenschlüssel  
 mit Zapfen  
 Hook wrench  
 with fixed pin  
 DIN1810 B 68x75

Copyright **EWS Tool Technologies**  
 Weitergabe und Vervielfältigung dieser Unterlage,  
 Verwertung und Mitteilung ihres Inhalts nicht  
 gestattet, soweit nicht ausdrücklich zugestanden.  
 Zuwiderhandlungen verpflichten zu Schadenersatz.

Bemerkung - Note

Technische Daten - technical data

Weight = 4.568 [kg]  
 Torque max. (M1/M2) = 63 / 63 [Nm]  
 Speed max. (n1/n2) = 6000 / 6000 [1/min]  
 Gear ratio (i)=n1:n2 = 1:1

Benennung - Title

**Axial Bohr und Fräskopf**  
**Axial drilling and milling head**



Nr. - No.  
**40.4040CTX#01**

Technische Änderungen vorbehalten!  
 Subject to technical modifications!

IDENT: DEWS247102



REV: -/A

MNR.

**229075**

