

Doppelverzahnung Lizenz Traub
double tooth system licence Traub

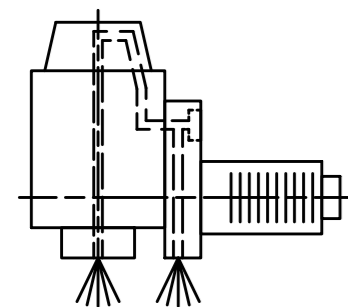

Innen- und Aussenkuehlung / Inside and outside coolant supply
Kuehlmittelfiltrierung-50 μ / coolant filtration-50 μ

Copyright **EWS Tool Technologies**
Weitergabe und Vervielfaeltigung dieser Unterlage,
Verwertung und Mitteilung ihres Inhalts nicht
gestattet, soweit nicht ausdrecklich zugestanden.
Zuwiderhandlungen verpflichten zu Schadenersatz.

Bemerkung - Note	Technische Daten - technical data
Für Trockenlauf geeignet! Use without coolant fluid allowed!	Weight = 5.365 [kg] Torque max. (M1/M2) = 32 / 32 [Nm] Speed max. (n1/n2) = 8000 / 8000 [1/min] Gear ratio (i)=n1:n2 = 1:1 Pressure (pmax) = 70 [bar]

Benennung - Title
Radial Bohr und Fräskopf, zurückges
Radial drill. and mill. head offset

EWS Tool Technologies	EWS Weigle GmbH & Co. KG Maybachstr. 1 D-73066 Uhlingen www.ews-tool.de	Technische Aenderungen vorbehalten! Subject to technical modifications!	IDENT: DEWS249532	REV: -/A
Nr. - No.	80.30VX3LTOEMRLIKDX100A35	MNR.	229038	QR