

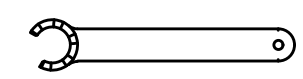

Butterfly Seal Coolant Management Tech Details

Fluchtungsfehlerausgleichend
misalignment compensating

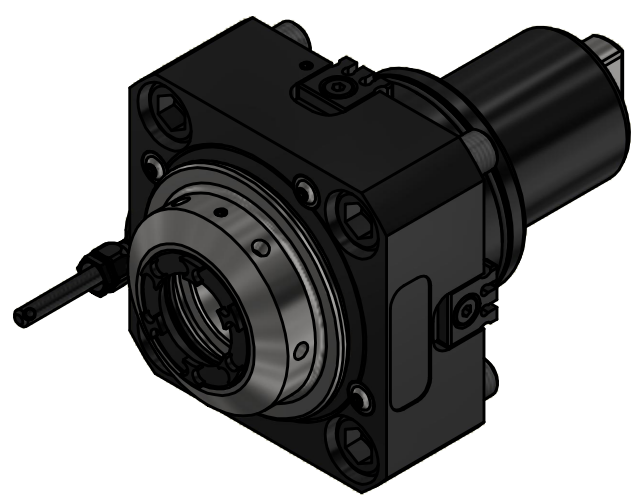
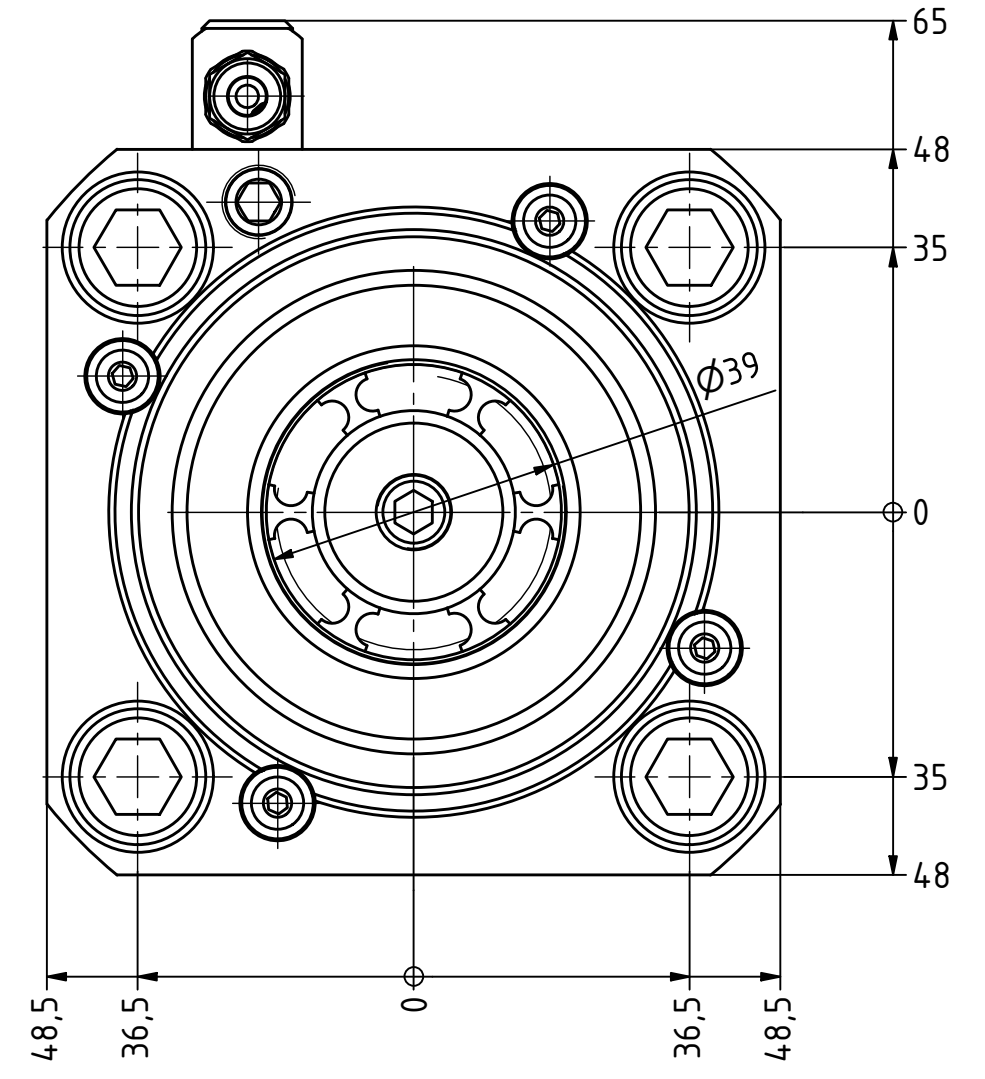
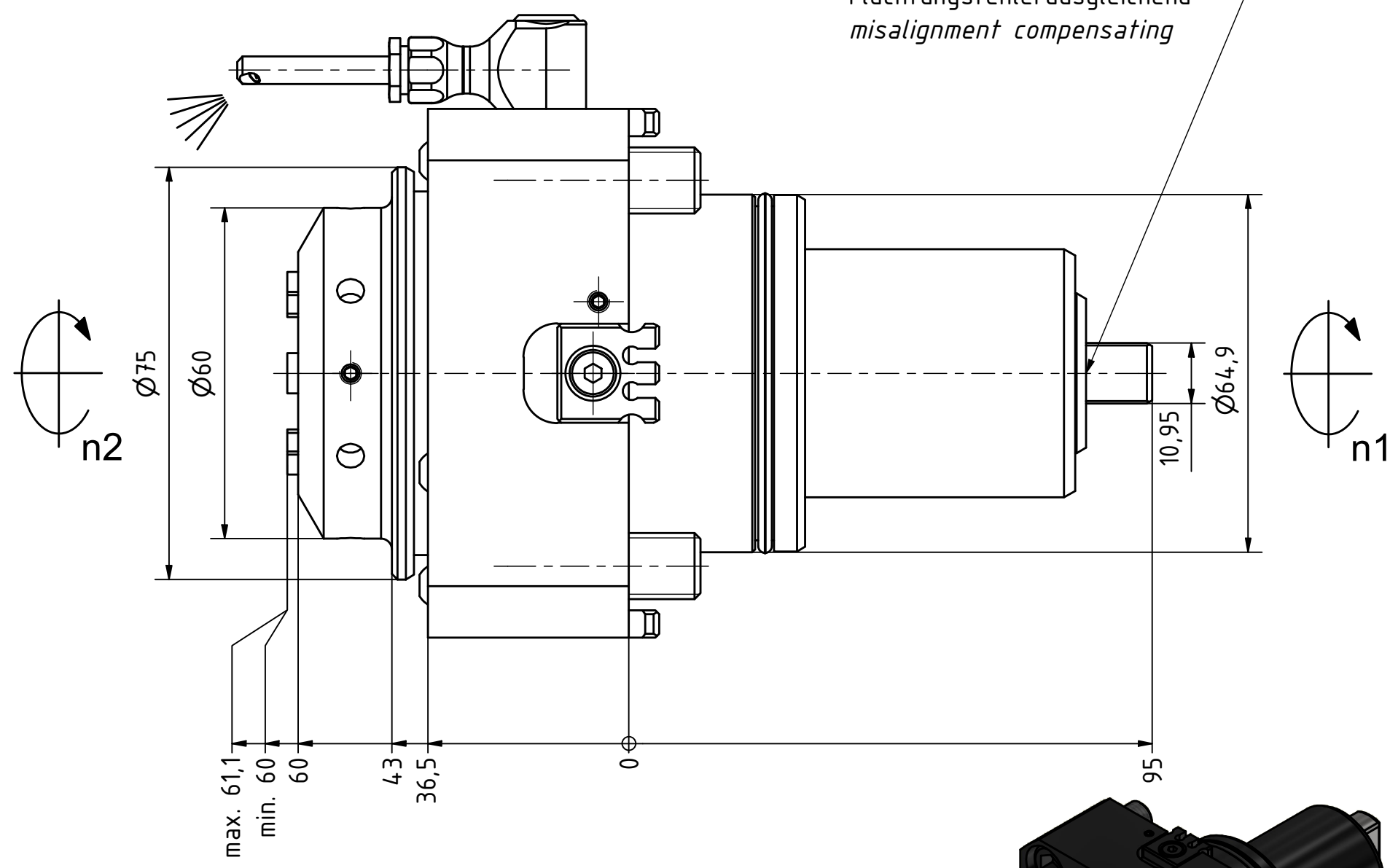

Spannzangenschlüssel für
innenliegende Mutter
Clamping wrench for
internal collet
232AX

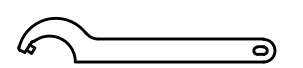

Hakenschlüssel
mit Zapfen
Hook wrench
with fixed pin
DIN1810 B 58x62

Spannzange / collet ER32 DIN6499
Spannbereich / clamping range: 2,0 - 20,0

Gewindebohrzange / tapping collet
ET-1-32 M5-M12

Copyright **EWS Tool Technologies**
Weitergabe und Vervielfaeltigung dieser Unterlage,
Verwertung und Mitteilung ihres Inhalts nicht
gestattet, soweit nicht ausdrecklich zugestanden.
Zuwiderhandlungen verpflichten zu Schadenersatz.

<p>Bemerkung - Note</p> <p>mit Kegelrollenlager with taper roller bearing(s)</p>	<p>Technische Daten - technical data</p> <p>Weight = 4.019 [kg] Torque max. (M1/M2) = 80 / 80 [Nm] Speed max. (n1/n2) = 5000 / 5000 [1/min] Gear ratio (i)=n1:n2 = 1:1</p>	<p>Benennung - Title</p> <p>Axial Bohr und Fräskopf Axial drilling and milling head</p>	<p>EWS Tool Technologies EWS Weigele GmbH & Co. KG Maybachstr. 1 D-73066 Utingen www.ews-tools.de</p>	<p>Technische Aenderungen vorbehalten! Subject to technical modifications!</p> <p>IDENT: DEWS242695</p>	<p>REV: -/A</p> <p>MNR.</p> <p>229085</p>	<p>QR</p>
--	--	---	--	---	---	------------------