

Spannzange / collet ER25 DIN6499
Spannbereich / clamping range: 1,0 - 16,0

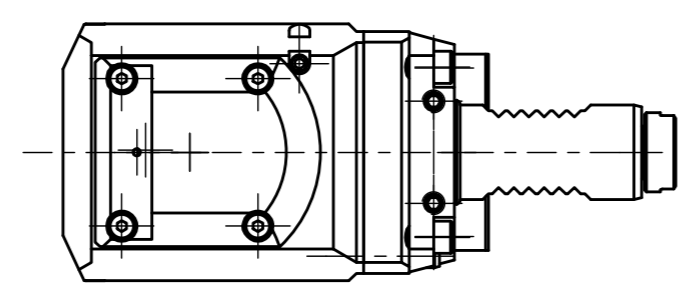

Doppelverzahnung Lizenz Traub
double tooth system licence Traub

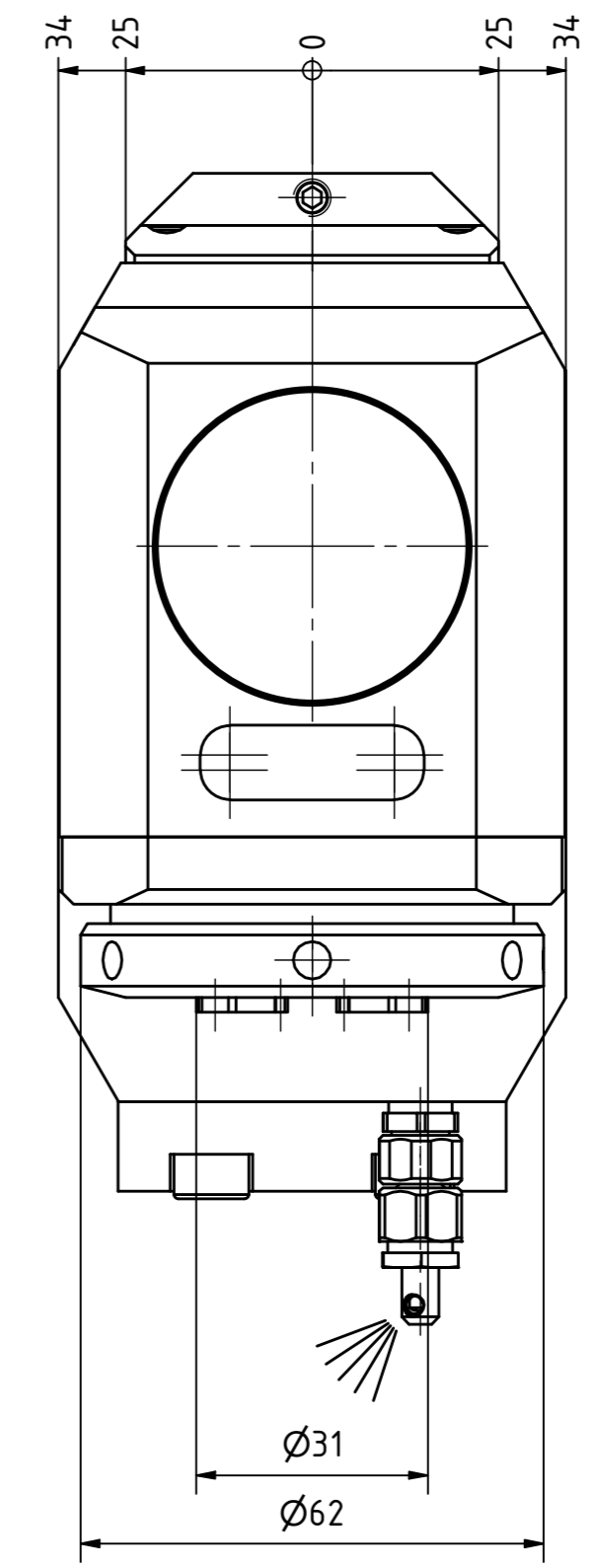
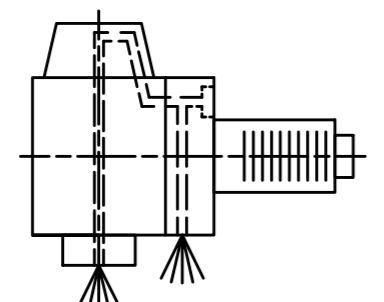

Innen- und Aussenkuehlung / Inside and outside coolant supply
Kuehlmittelfiltrierung=50µ / coolant filtration=50µ

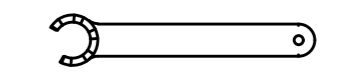
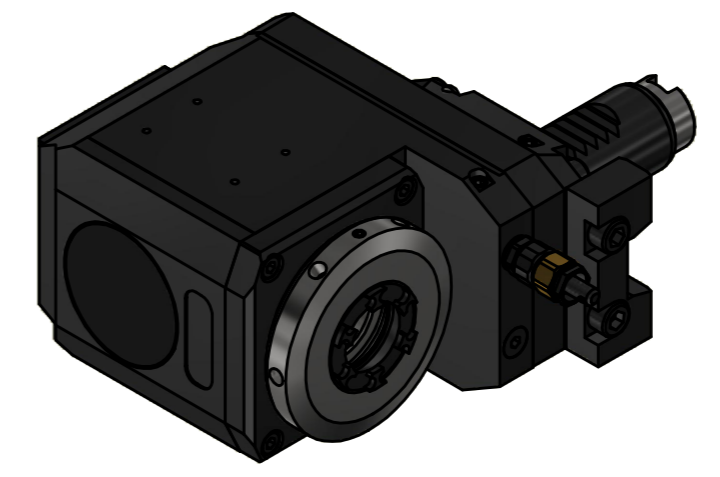

Spannzangenschlüssel für innenliegende Mutter
Clamping wrench for internal collet
225AX

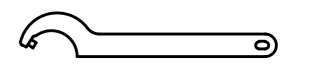

Hakenschlüssel mit Zapfen
Hook wrench with fixed pin
DIN1810 B 58x62

Copyright EWS Tool Technologies
Weitergabe und Vervielfaeltigung dieser Unterlage, Verwertung und Mitteilung ihres Inhalts nicht gestattet, soweit nicht ausdrecklich zugestanden. Zuwiderhandlungen verpflichten zu Schadenersatz.

Bemerkung - Note Für Trockenlauf geeignet! Use without coolant fluid allowed!	Technische Daten - technical data Weight = 4.323 [kg]
	Torque max. (M1/M2) = 25 / 25 [Nm]
	Speed max. (n1/n2) = 8000 / 8000 [1/min]
	Gear ratio (i)=n1:n2 = 1:1
	Pressure (pmax) = 70 [bar]

Benennung - Title
Radial Bohr und Fräskopf, zurückges
Radial drill. and mill. head offset

EWS Tool Technologies <small>EWS Weigle GmbH & Co. KG Maybachstr. 1 D-73066 Uhlingen www.ews-tool.de</small>	Technische Aenderungen vorbehalten! Subject to technical modifications! IDENT: DEWS247053	REV: -/A MNR.
	Nr. - No. 80.2525G200RLIKDVIM#01	229112

