

Spannzange / collet ER32 DIN6499  
 Spannungsbereich / clamping range: 2,0 - 20,0

Gewindebohrzange / tapping collet  
 ET-1-32 M5-M12

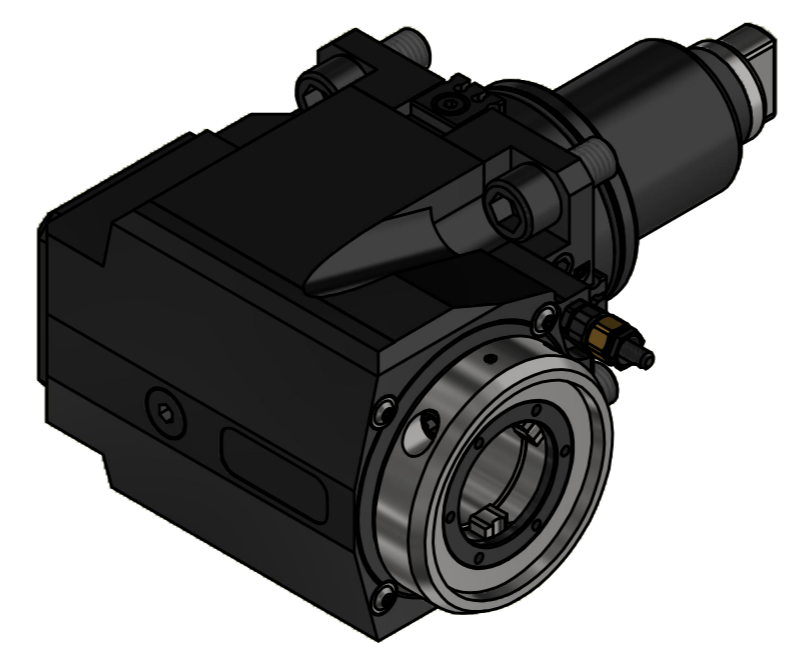

Copyright EWS Tool Technologies  
 Weitergabe und Vervielfältigung dieser Unterlage,  
 Verwertung und Mitteilung ihres Inhalts nicht  
 gestattet, soweit nicht ausdrücklich zugestanden.  
 Zuwiderhandlungen verpflichten zu Schadenersatz.

Bemerkung - Note  mit Kegelrollenlager with taper roller bearing(s)	Technische Daten - technical data Weight = 8.607 [kg] Torque max. (M1/M2) = 80 / 80 [Nm] Speed max. (n1/n2) = 5000 / 5000 [1/min] Gear ratio (i)=n1:n2 = 1:1	Benennung - Title  <b>Radial Bohr und Fräskopf</b> <b>Radial drilling and milling head</b>	EWS Weigle GmbH & Co. KG Maybachstr. 1 D-73066 Uhingen www.ews-tool.de Technische Änderungen vorbehalten! Subject to technical modifications! IDENT: DEWS242802 Nr. - No. 60.65VX4KRVL6FGL MNR. 229099 REV: -/A	QR
--	--	---	--	----