

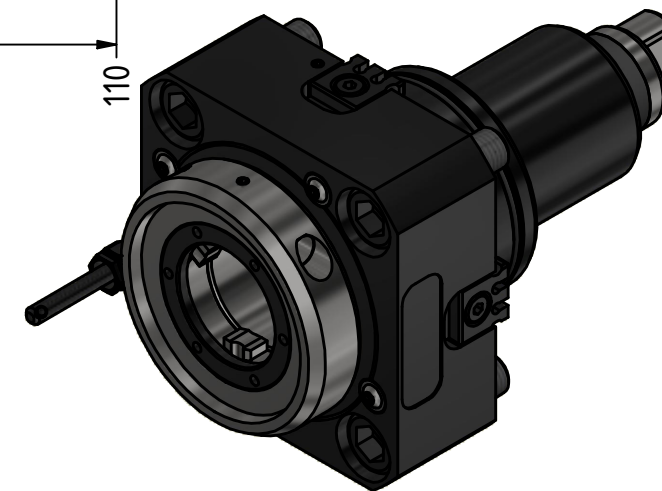

EWS.Varia Ceramic Seal Butterfly Seal Coolant Management Tech Details

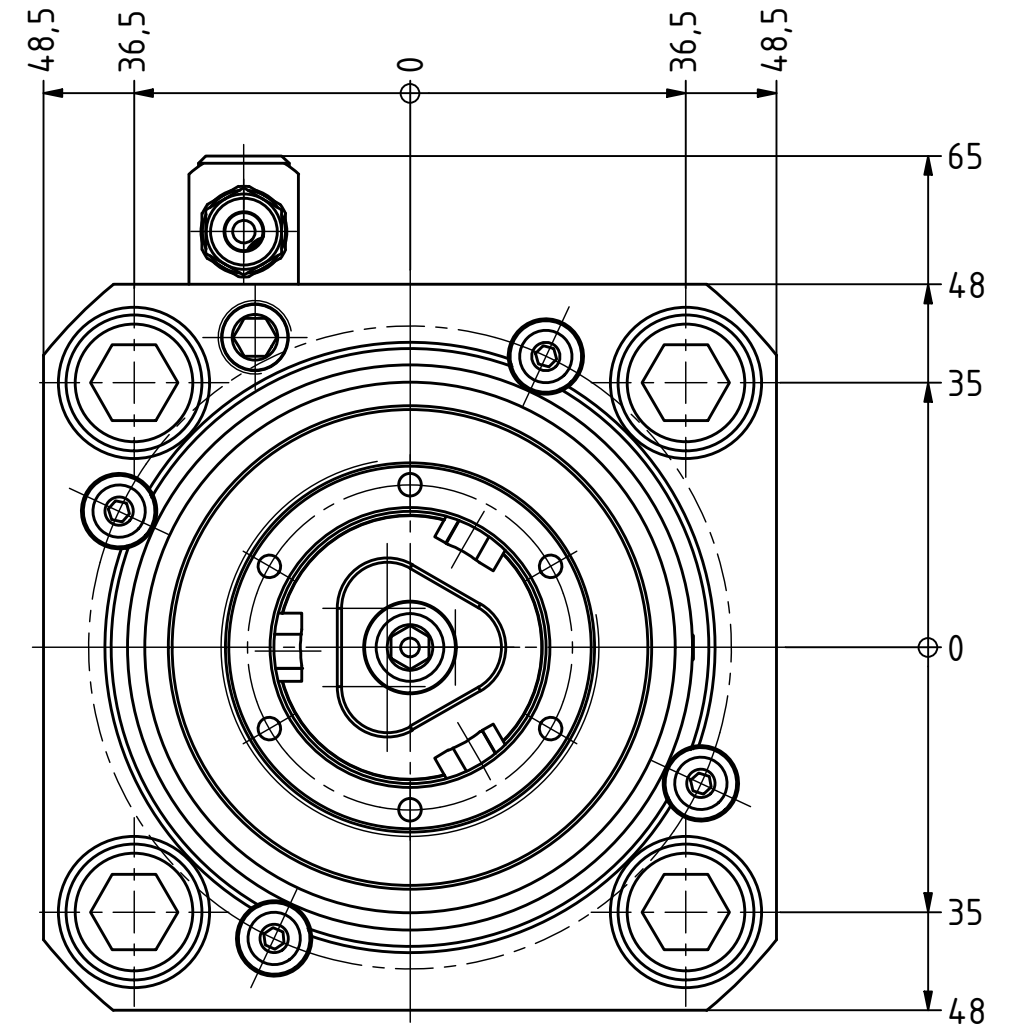
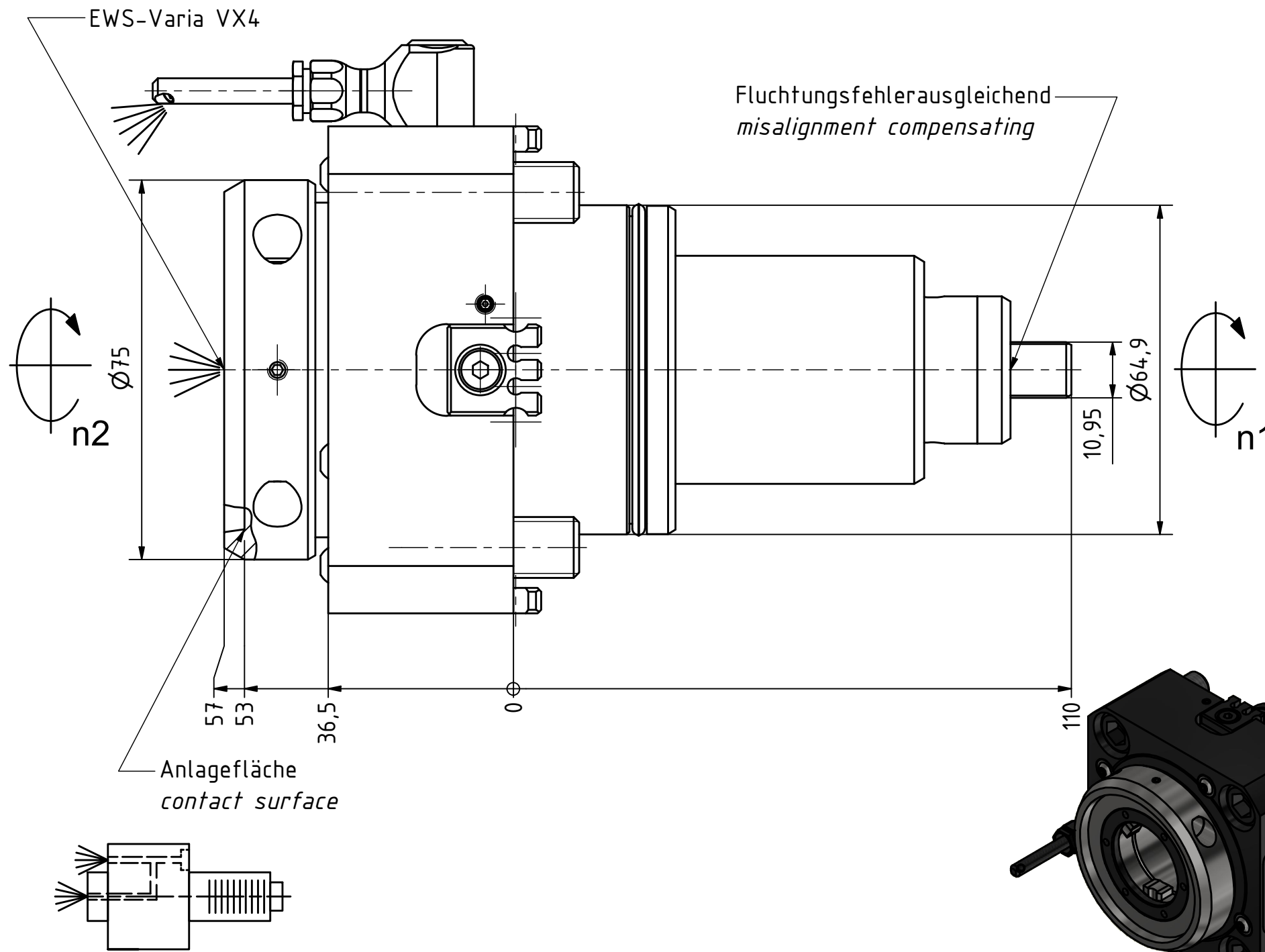

Innen- und Aussenkuehlung / Inside and outside coolant supply
Kuehlmittelfiltrierung <math>< 50\mu</math> / coolant filtration <math>< 50\mu</math>

Copyright **EWS Tool Technologies**
Weitergabe und Vervielfaeltigung dieser Unterlage,
Verwertung und Mitteilung ihres Inhalts nicht
gestattet, soweit nicht ausdruercklich zugestanden.
Zuwiderhandlungen verpflichten zu Schadenersatz.

Bemerkung - Note
Für Trockenlauf geeignet!
Use without coolant fluid allowed!
mit Kegelrollenlager
with taper roller bearing(s)

Technische Daten - technical data	
Weight	= 4.161 [kg]
Torque max. (M1/M2)	= 80 / 80 [Nm]
Speed max. (n1/n2)	= 5000 / 5000 [1/min]
Gear ratio (i)=n1:n2	= 1:1
Pressure (pmax)	= 70 [bar]

Benennung - Title
Axial Bohr und Fräskopf
Axial drilling and milling head

EWS Tool Technologies
EWS Weigle GmbH & Co. KG
Maybachstr. 1
D-73066 Utingen
www.ews-tools.de

Nr. - No.
40.65VX4KRVL6FIKD

Technische Aenderungen vorbehalten! <i>Subject to technical modifications!</i>	
IDENT: DEWS242557	REV: -/A
MNR.	229083

