

Spannzange / collet ER25 DIN6499
Spannbereich / clamping range: 1,0 - 16,0

Gewindebohrzange / tapping collet
ET-1-25 M3-M12

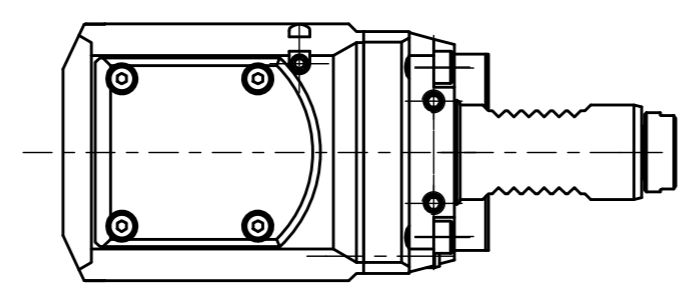

Doppelverzahnung Lizenz Traub
double tooth system licence Traub

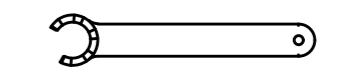
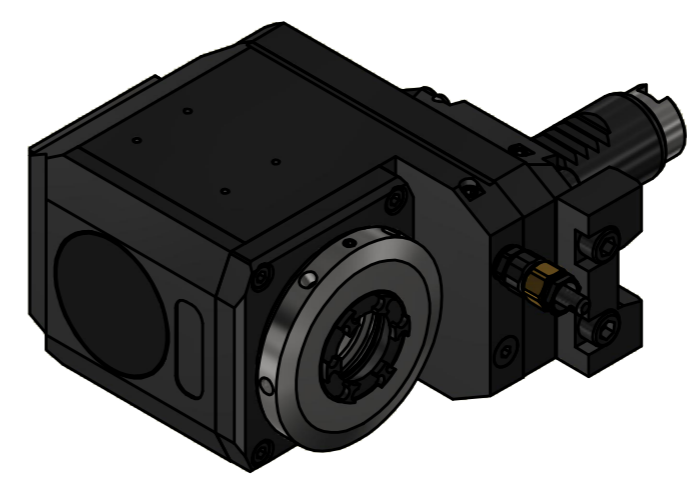

Spannzangenschlüssel für innenliegende Mutter
Clamping wrench for internal collet
225AX

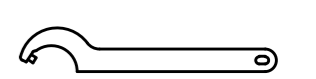

Hakenschlüssel mit Zapfen
Hook wrench with fixed pin
DIN1810 B 58x62

Copyright EWS Tool Technologies
Weitergabe und Vervielfältigung dieser Unterlage, Verwertung und Mitteilung ihres Inhalts nicht gestattet, soweit nicht ausdrücklich zugestanden. Zuwiderhandlungen verpflichten zu Schadenersatz.

Benennung - Title	Technische Daten - technical data
	Weight = 4,222 [kg]
	Torque max. (M1/M2) = 25 / 25 [Nm]
	Speed max. (n1/n2) = 8000 / 8000 [1/min]
	Gear ratio (i)=n1:n2 = 1:1

Benennung - Title
Radial Bohr und Fräskopf, zurückges
Radial drill. and mill. head offset

EWS Tool Technologies	EWS Weigle GmbH & Co. KG Maybachstr. 1 D-73066 Uhlingen www.ews-tools.de	Technische Änderungen vorbehalten! Subject to technical modifications!	REV: -/A
	Nr. - No. 80.2525G200RLVIM#01	IDENT: DEWS247066	

