

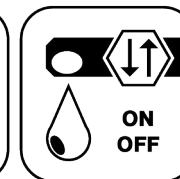

Ceramic Seal



Butterfly Seal



Coolant Management



Tech Details

Spannzange / collet ER32 DIN6499
Spannbereich / clamping range: 2,0 - 20,0

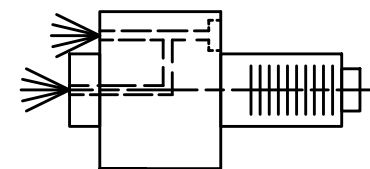
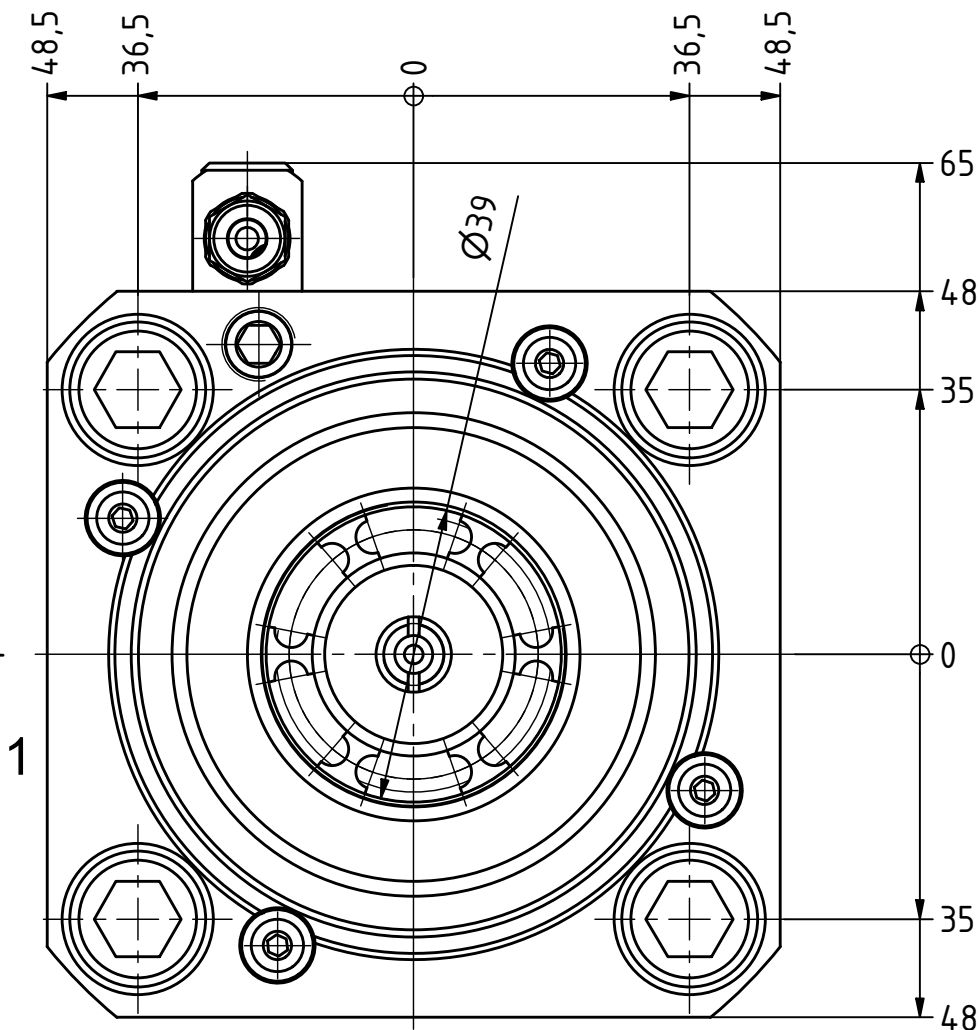
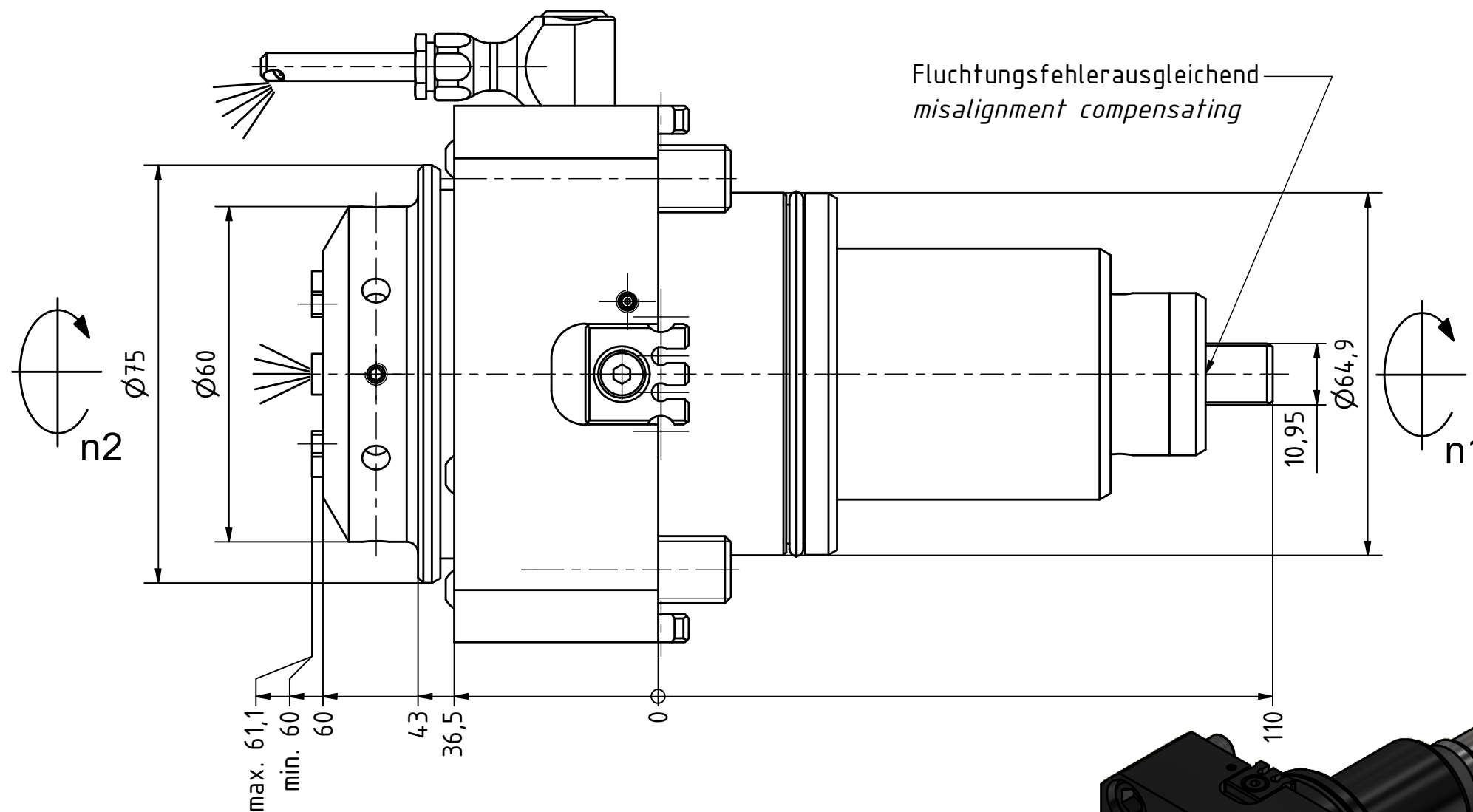

Innen- und Aussenkuehlung / Inside and outside coolant supply
Kuehlmittelfiltrierung < 50µ / coolant filtration < 50µ

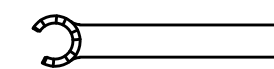

Spannzangenschlüssel für innenliegende Mutter
Clamping wrench for internal collet
232AX



Hakenschlüssel mit Zapfen
Hook wrench with fixed pin
DIN1810 B 58x62

Copyright **EWS Tool Technologies**
Weitergabe und Vervielfaeltigung dieser Unterlage, Verwertung und Mitteilung ihres Inhalts nicht gestattet, soweit nicht ausdrecklich zugestanden. Zuwiderhandlungen verpflichten zu Schadenersatz.

Bemerkung - Note
Für Trockenlauf geeignet!
Use without coolant fluid allowed!
mit Kegelrollenlager
with taper roller bearing(s)

Technische Daten - technical data

| | |
|----------------------|-----------------------|
| Weight | = 4.213 [kg] |
| Torque max. (M1/M2) | = 80 / 80 [Nm] |
| Speed max. (n1/n2) | = 5000 / 5000 [1/min] |
| Gear ratio (i)=n1:n2 | = 1:1 |
| Pressure (pmax) | = 70 [bar] |

Benennung - Title
Axial Bohr und Fräskopf
Axial drilling and milling head

EWS Tool Technologies
EWS Weigle GmbH & Co. KG
Maybachstr. 1
D-73066 Uthingen
www.ews-tools.de

Technische Aenderungen vorbehalten!
Subject to technical modifications!
IDENT: DEWS242534
REV: -/A
MNR.
229081

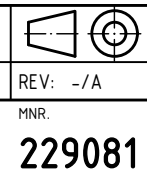

QR