

Spannzange / collet ER32 DIN6499
 Spannbereich / clamping range: 2,0 - 20,0

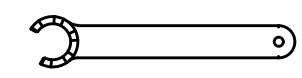

Spannzangenschlüssel für
 innenliegende Mutter
 Clamping wrench for
 internal collet
 232AX

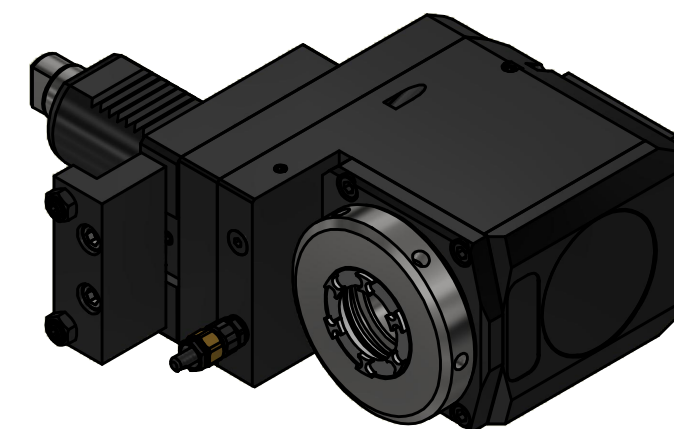
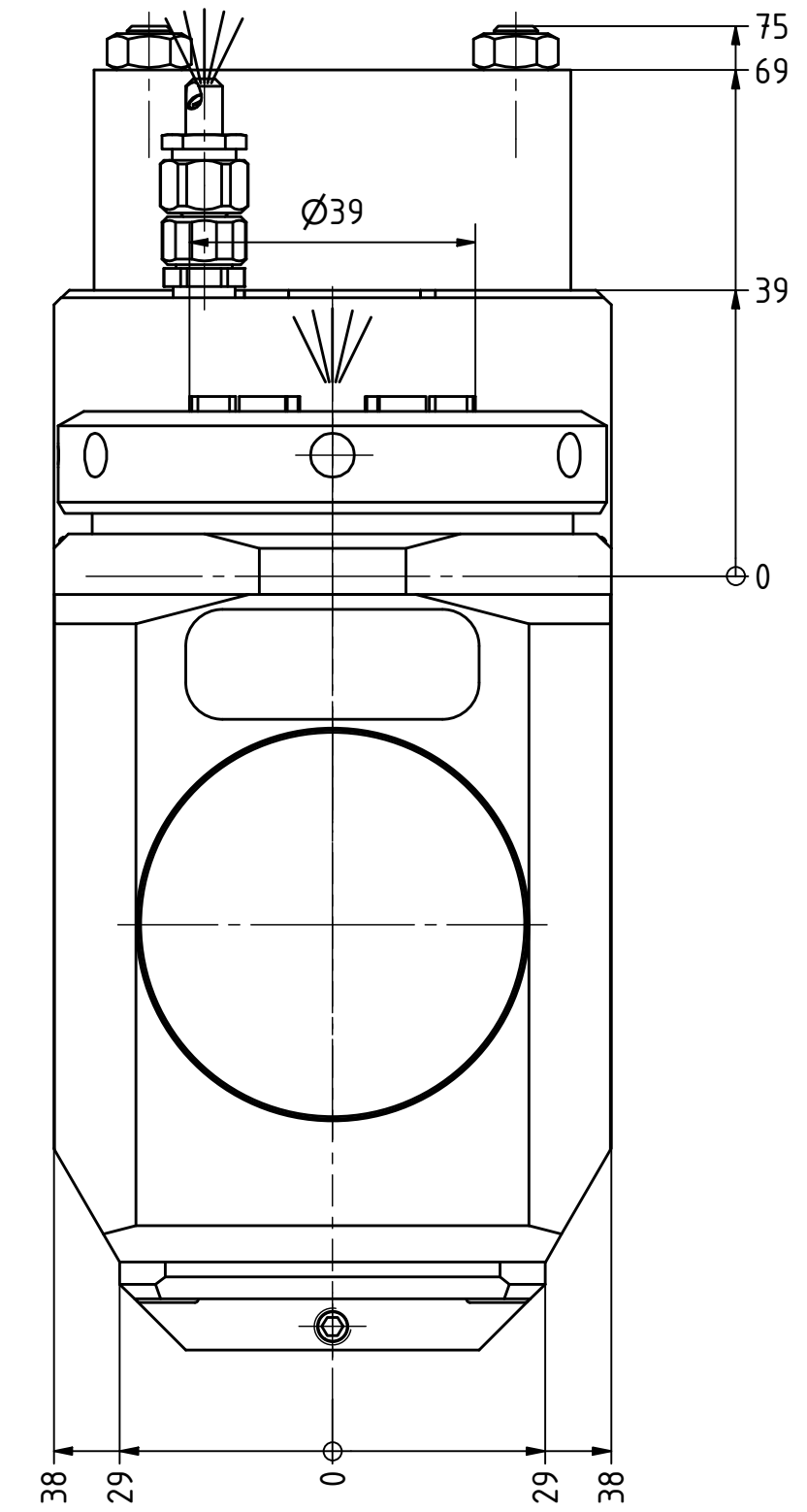
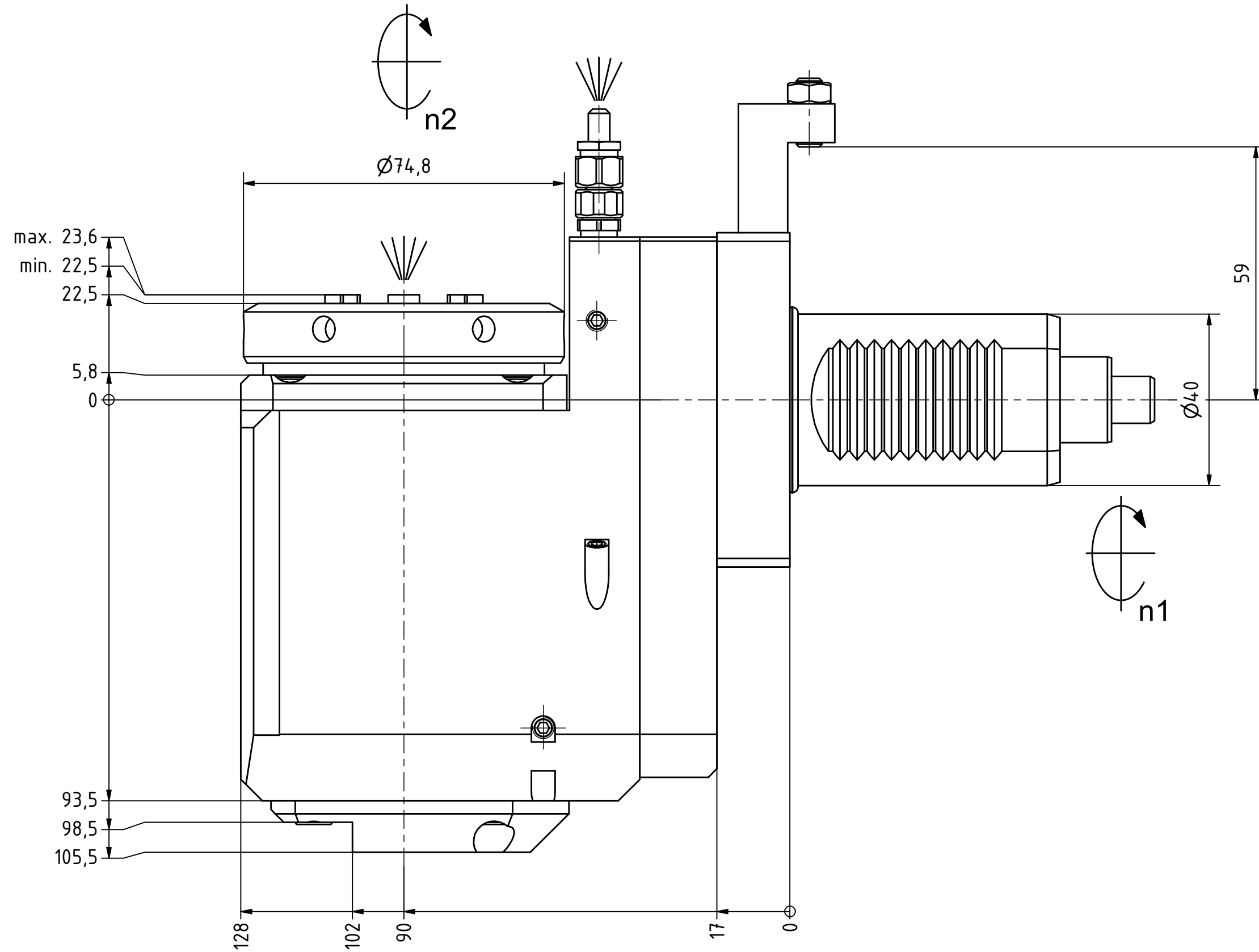
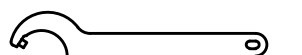

Hakenschlüssel
 mit Zapfen
 Hook wrench
 with fixed pin
 DIN1810 B 68x75

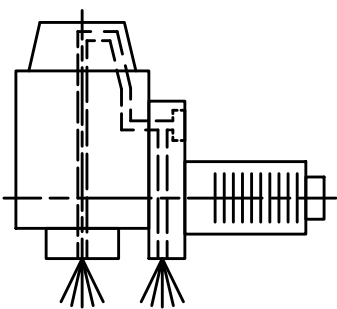

Innen- und Aussenkuehlung / Inside and outside coolant supply
 Kuehlmittelfiltrierung+50µ / coolant filtration+50µ

Copyright **EWS Tool Technologies**
 Weitergabe und Vervielfaeltigung dieser Unterlage,
 Verwertung und Mitteilung ihres Inhalts nicht
 gestattet, soweit nicht ausdrecklich zugestanden.
 Zuwiderhandlungen verpflichten zu Schadenersatz.

Bemerkung - Note Für Trockenlauf geeignet! Use without coolant fluid allowed!	Technische Daten - technical data Weight = 7.717 [kg] Torque max. (M1/M2) = 63 / 63 [Nm] Speed max. (n1/n2) = 6000 / 6000 [1/min] Gear ratio (i)=n1:n2 = 1:1 Pressure (pmax) = 70 [bar]	Benennung - Title Radial Bohr und Fräskopf, zurückges Radial drill. and mill. head offset	EWS EWS Weigle GmbH & Co. KG Maybachstr. 1 D-73066 Uhlingen www.ews-tools.de	Technische Aenderungen vorbehalten! Subject to technical modifications! IDENT: DEWS246954 REV: -/A	 QR 80.4032VLP3LIKDIM 229078
---	--	---	--	---	--