

Polygon ISO 26623 PSC 40

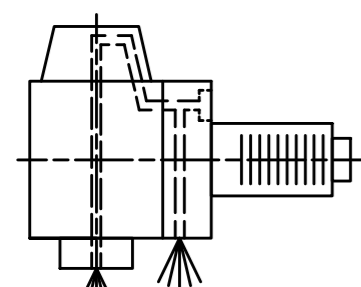
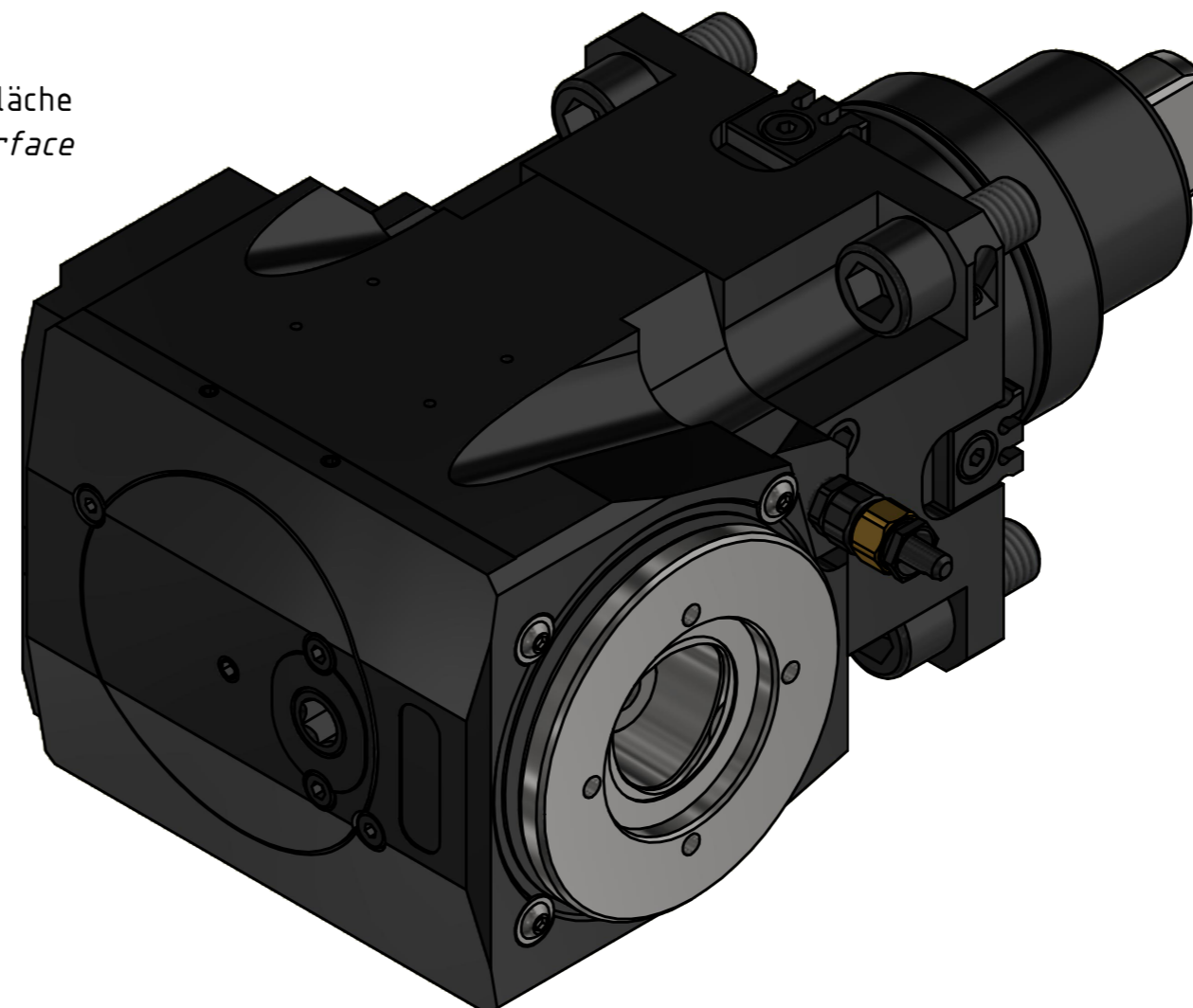

Innen- und Aussenkühlung / Inside and outside coolant supply
Kuehlmittefiltrierung-50µ / coolant filtration-50µ

<p>Bemerkung - Note Für Trockenlauf geeignet! Use without coolant fluid allowed!</p>	<p>Technische Daten - technical data Weight = 9.930 [kg] Torque max. (M1/M2) = 80 / 80 [Nm] Speed max. (n1/n2) = 6000 / 6000 [1/min] Gear ratio (i)=n1:n2 = 1:1 Pressure (pmax) = 70 [bar]</p>	<p>Benennung - Title Radial Bohr und Fräskopf Radial drilling and milling head</p>	<p>EWS Tool Technologies EWS Weigle GmbH & Co. KG Maybachstr. 1 D-73066 Uhingen www.ews-tool.de</p> <p>Technische Änderungen vorbehalten! Subject to technical modifications! IDENT: DEWS240141 REV: -/B MNR. 229002</p> <p>Nr. - No. 60.65C41809MT110FIKDX100</p> <p>QR</p>
--	--	--	---

Copyright EWS Tool Technologies
Weitergabe und Vervielfältigung dieser Unterlage,
Verwertung und Mitteilung ihres Inhalts nicht
gestattet, soweit nicht ausdrücklich zugestanden.
Zuwendungen verpflichten zu Schadenersatz.