

Spannzange / collet ER25 DIN6499  
Spannbereich / clamping range: 1,0 - 16,0

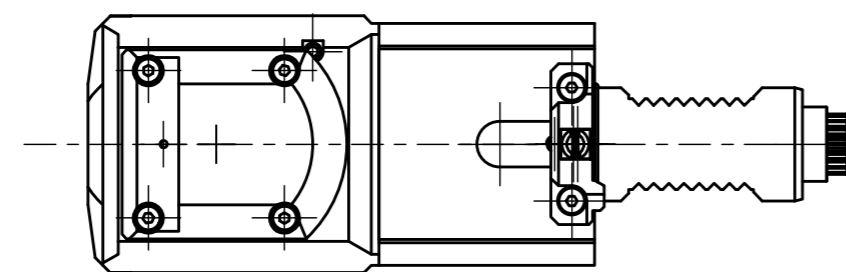

Doppelverzahnung Lizenz Traub  
double tooth system licence Traub

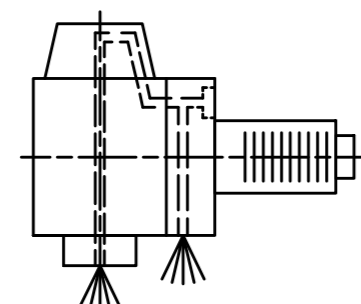

Innen- und Aussenkuehlung / Inside and outside coolant supply  
Kuehlmittelfiltrierung-50µ / coolant filtration-50µ

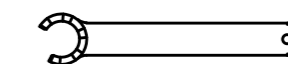
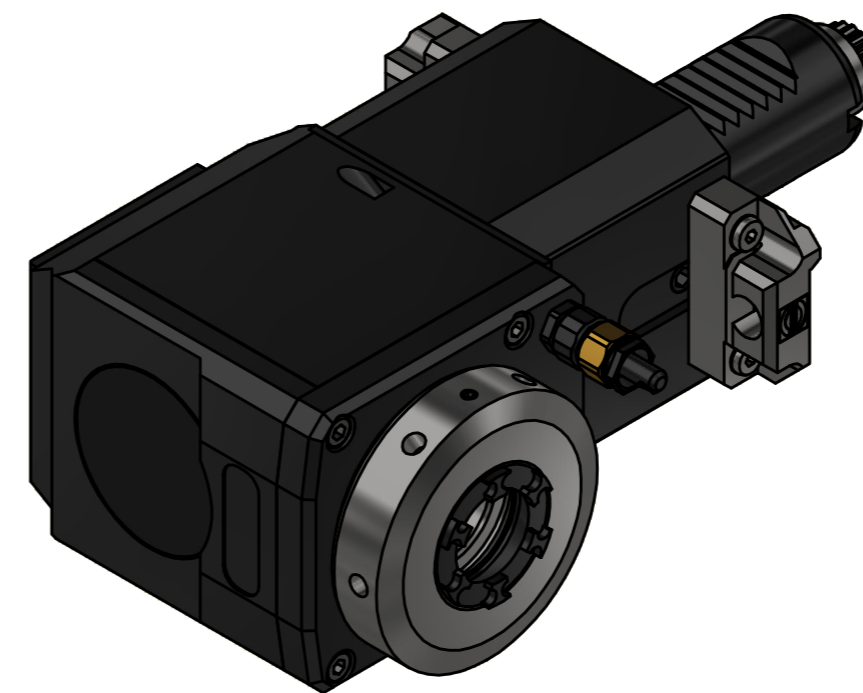

Spannzangenschlüssel für  
innenliegende Mutter  
Clamping wrench for  
internal collet  
225AX

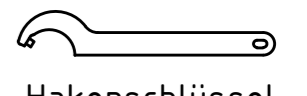

Hakenschlüssel  
mit Zapfen  
Hook wrench  
with fixed pin  
DIN1810 B 58x62  
225AX

Copyright **EWS Tool Technologies**  
Weitergabe und Vervielfaeltigung dieser Unterlage,  
Verwertung und Mitteilung ihres Inhalts nicht  
gestattet, soweit nicht ausdrucklich zugestanden.  
Zuwoerhandlungen verpflichten zu Schadenersatz.

Bemerkung - Note  
Für Trockenlauf geeignet!  
Use without coolant fluid allowed!

Technische Daten - technical data  
Weight = 4.824 [kg]  
Torque max. (M1/M2) = 24 / 12 [Nm]  
Speed max. (n1/n2) = 6000 / 12000 [1/min]  
Gear ratio (i)=n1:n2 = 1:2  
Pressure (pmax) = 70 [bar]

Benennung - Title  
**Radial Bohr und Fräskopf**  
**Radial drilling and milling head**

	<small>EWS Weigela GmbH &amp; Co. KG Maybachstr. 1 D-73066 Uhlingen www.ews-tools.de</small>	Technische Aenderungen vorbehalten! Subject to technical modifications!	
		IDENT: DEWS246819	
Nr. - No. <b>60.3025LCTXRLIKD1TFRIM</b>		MNR. <b>228879</b>	