

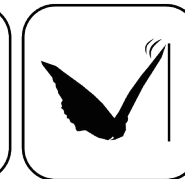

Ceramic Seal

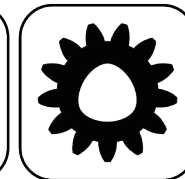

Butterfly Seal



Polygon Joint

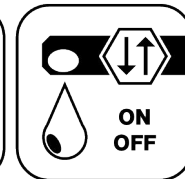

Coolant Management



Tech Details

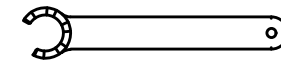
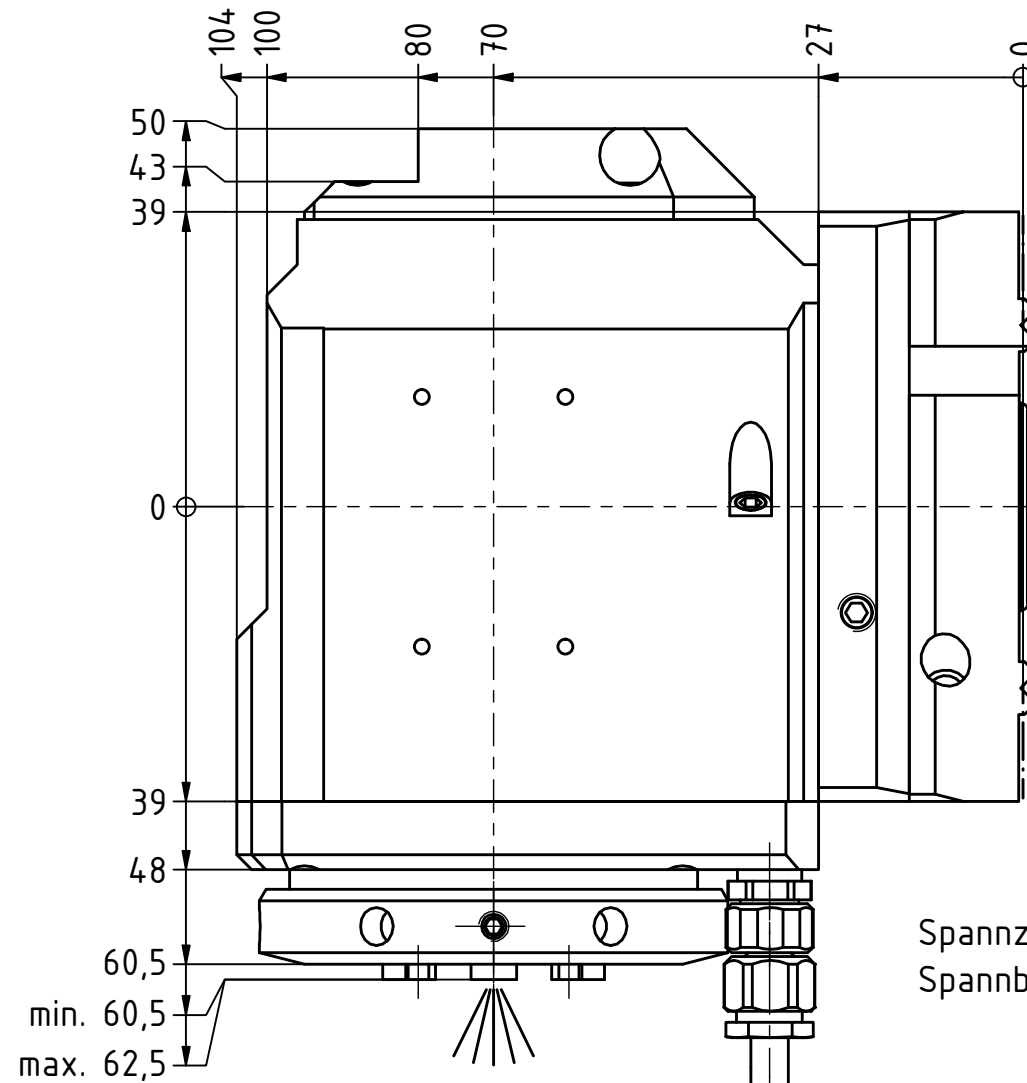

Spannzangenschlüssel für innenliegende Mutter  
Clamping wrench for internal collet  
225AX

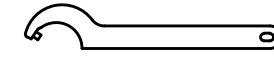

Hakenschlüssel mit Zapfen  
Hook wrench with fixed pin  
DIN1810 B 58x62

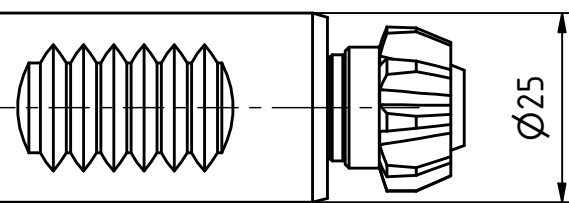

W-Verzahnung Lizenz Index-Werke  
W-tooth system licence Index-Corporation

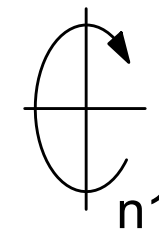

Spannzange / collet ER25 DIN6499  
Spannbereich / clamping range: 1,0 - 16,0

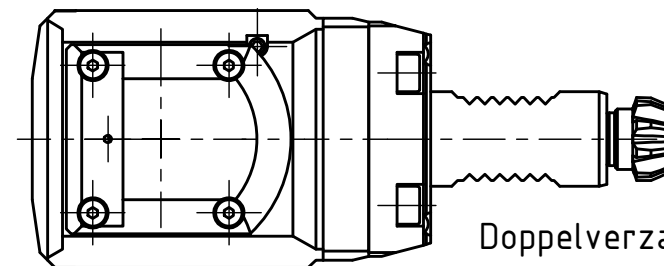
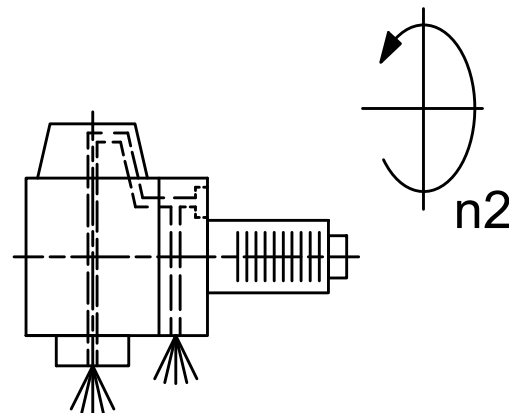
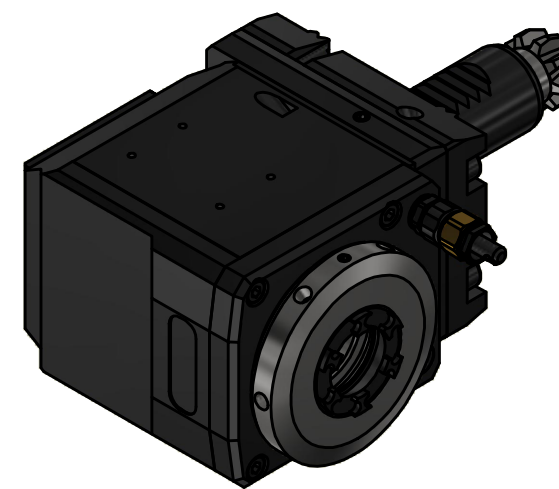
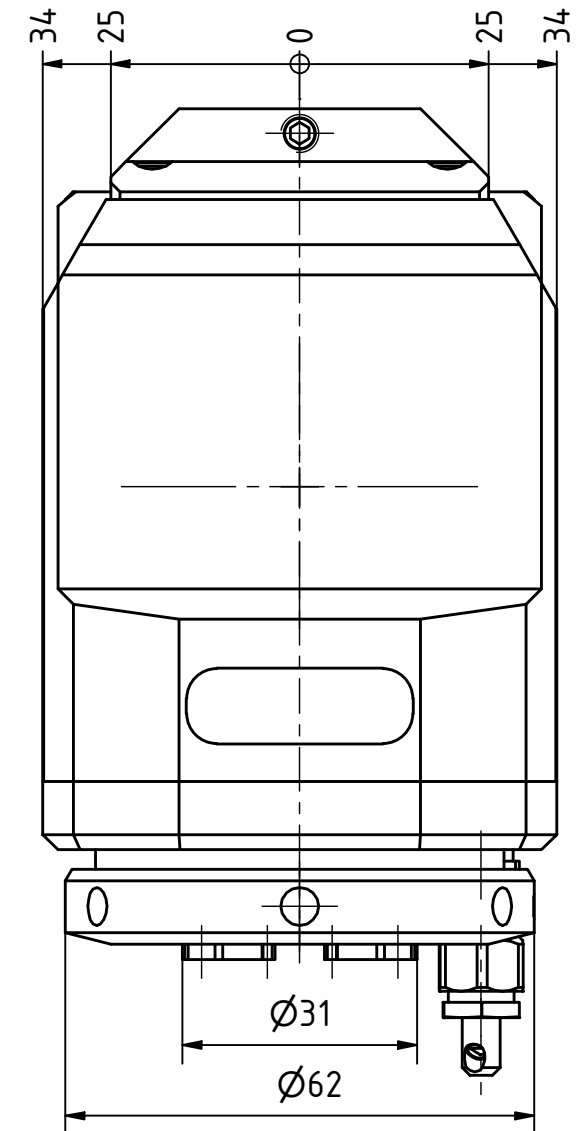

Doppelverzahnung Lizenz Traub  
double tooth system licence Traub

Innen- und Aussenkuehlung / Inside and outside coolant supply  
Kuehlmittelfiltrierung <50µ / coolant filtration <50µ

Copyright **EWS Tool Technologies**  
Weitergabe und Vervielfaeltigung dieser Unterlage,  
Verwertung und Mitteilung ihres Inhalts nicht  
gestattet, soweit nicht ausdrecklich zugestanden.  
Zuwiderhandlungen verpflichten zu Schadenersatz.

Bemerkung - Note  
Für Trockenlauf geeignet!  
Use without coolant fluid allowed!

Technische Daten - technical data

Weight	=	4.076 [kg]
Torque max. (M1/M2)	=	25 / 25 [Nm]
Speed max. (n1/n2)	=	8000 / 8000 [1/min]
Gear ratio (i)=n1:n2	=	1:1
Pressure (pmax)	=	70 [bar]

Benennung - Title  
**Radial Bohr und Fräskopf**  
**Radial drilling and milling head**



Nr. - No.  
**60.2525ABCRLIKDWIM**

Technische Aenderungen vorbehalten!  
Subject to technical modifications!

IDENT: DEWS262479

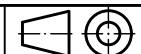

REV: -/A

MNR.  
**228886**

