

Spannzange / collet ER25 DIN6499
Spannbereich / clamping range: 1,0 - 16,0

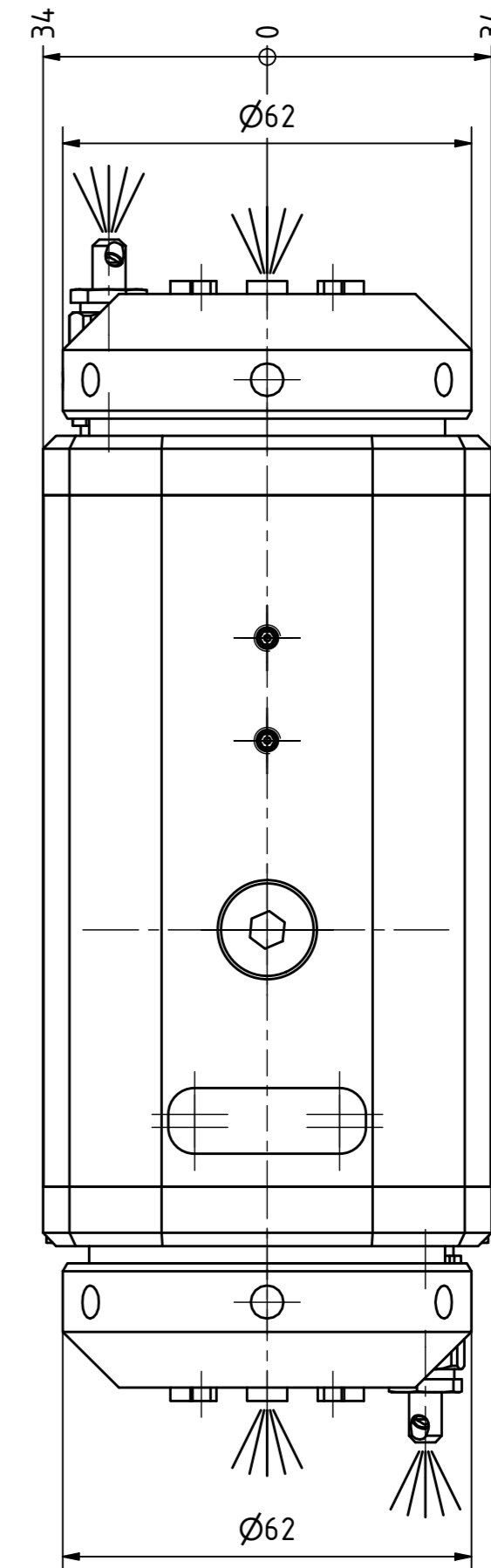

Spannzange / collet ER25 DIN6499
Spannbereich / clamping range: 1,0 - 16,0

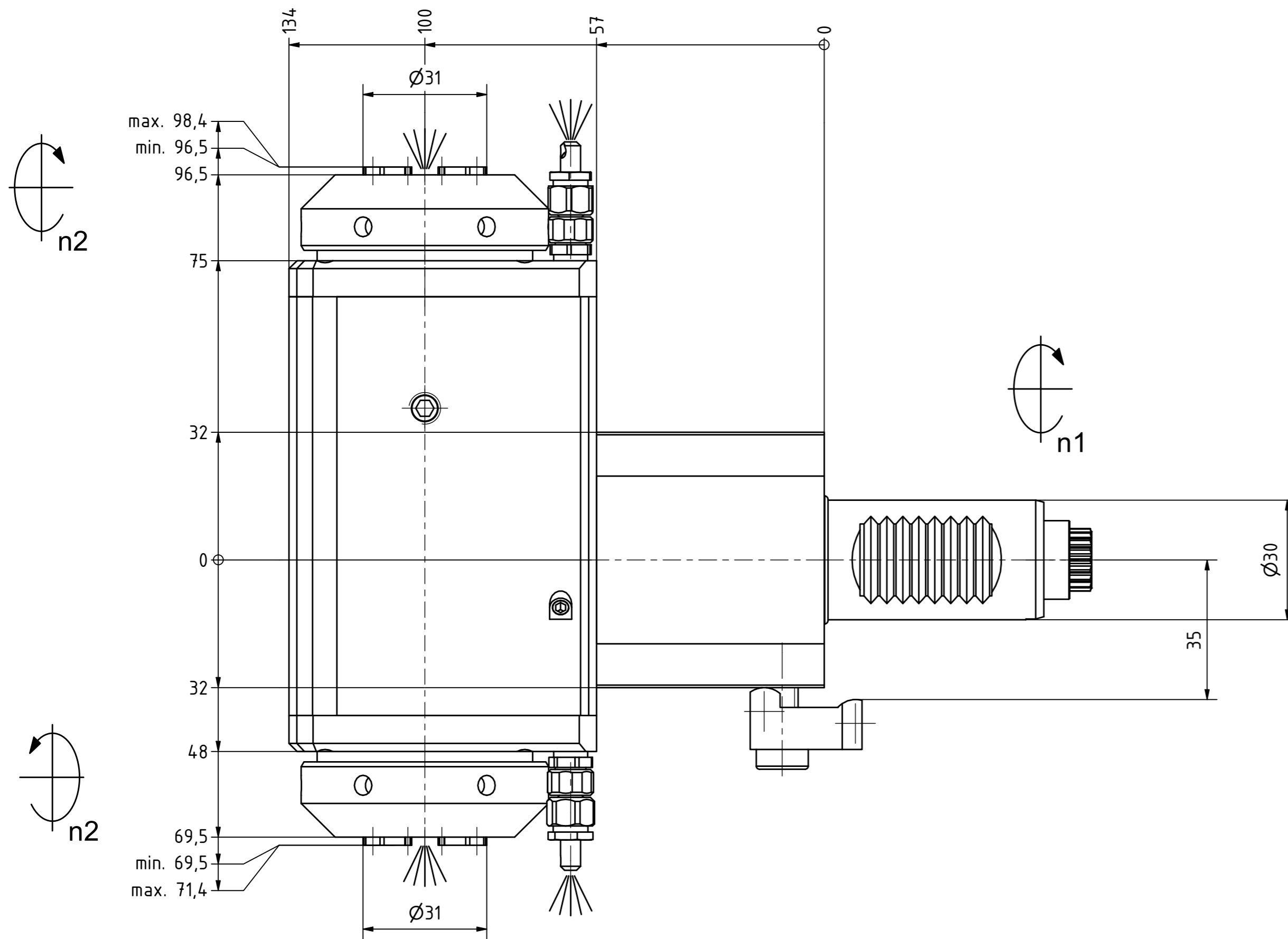
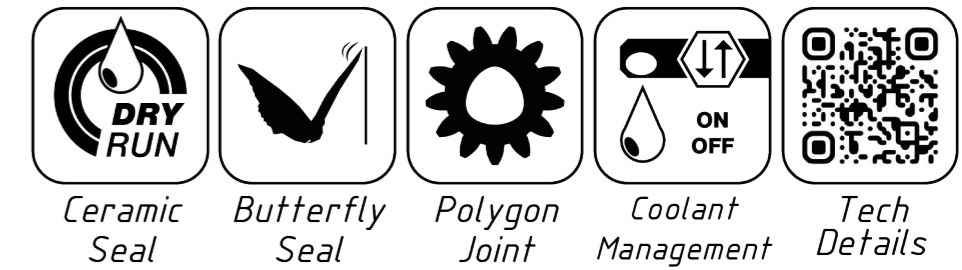
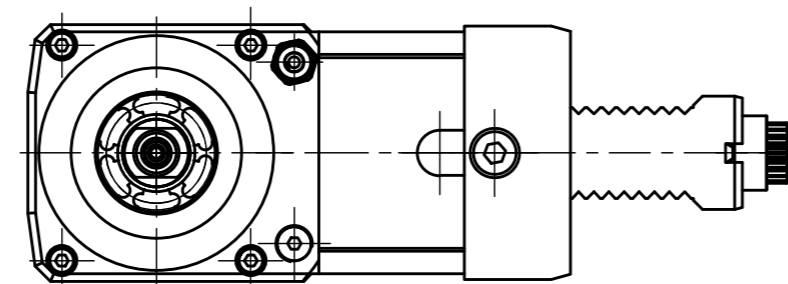

Doppelverzahnung Lizenz Traub
double tooth system licence Traub

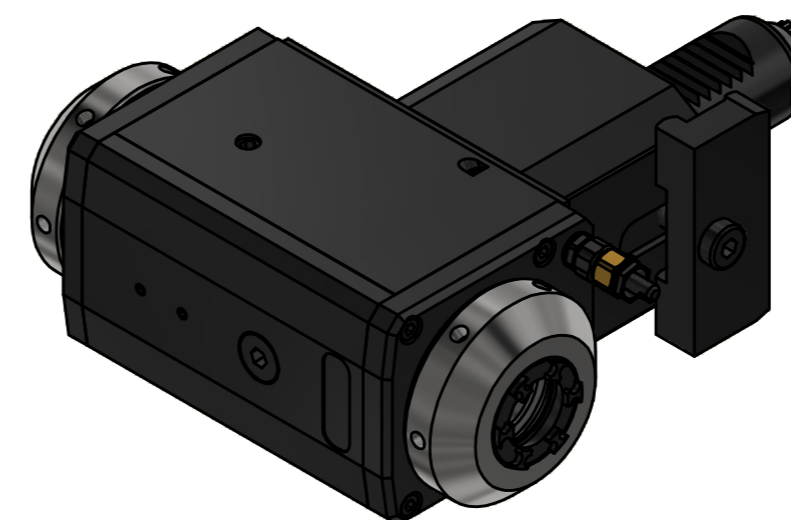

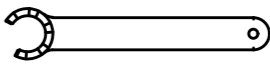
Spannzangenschlüssel für
innenliegende Mutter
Clamping wrench for
internal collet
225AX

Hakenschlüssel
mit Zapfen
Hook wrench
with fixed pin
DIN1810 B 58x62

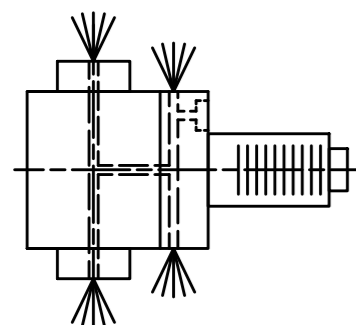

Innen- und Aussenkuehlung / Inside and outside coolant supply
Kuehlmittelfiltrierung=50µ / coolant filtration=50µ

Copyright **EWS Tool Technologies**
Weitergabe und Vervielfaeltigung dieser Unterlage,
Verwertung und Mitteilung ihres Inhalts nicht
gestattet, soweit nicht ausdrucklich zugestanden.
Zuwiderhandlungen verpflichten zu Schadenersatz.

Bemerkung - Note Für Trockenlauf geeignet! Use without coolant fluid allowed!	Technische Daten - technical data
	Weight = 6.831 [kg]
	Torque max. (M1/M2) = 32 / 32 32 [Nm]
	Speed max. (n1/n2) = 8000 / 8000 8000 [1/min]
	Gear ratio (i)=n1:n2 = 1:1 1:1
Pressure (pmax) = 70 [bar]	

Benennung - Title
Radial Bohr und Fräskopf
Radial drilling and milling head

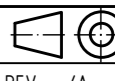
EWS Tool Technologies	EWS Weigle GmbH & Co. KG Maybachstr. 1 D-73066 Ulm/ingen www.ews-tool.de	Technische Aenderungen vorbehalten! Subject to technical modifications!	
	IDENT: DEWS244713	REV: -/A	
Nr. - No. 60.3025DE365RLIKCOT13IM	MNR. 228761	