

Spannzange / *collet* ER25 DIN6499
 Spannbereich / *clamping range*: 1,0 - 16,0

Gewindebohrzange / *tapping collet*
 ET-1-25 M3-M12

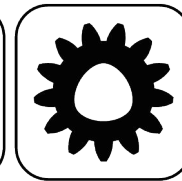

Butterfly
Seal



Polygon
Joint



Coolant
Management



Tech
Details

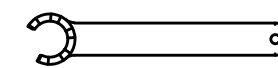
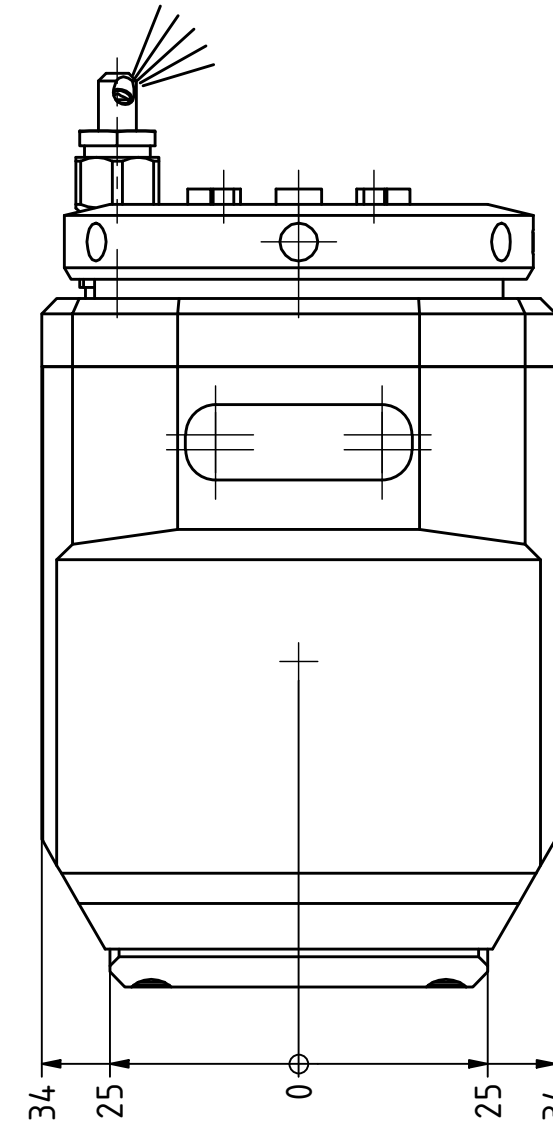
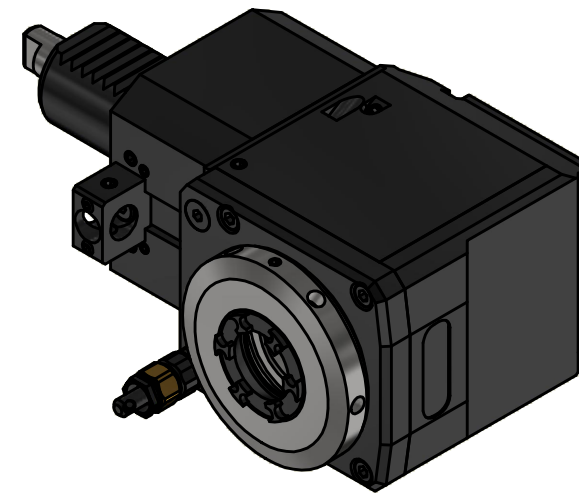
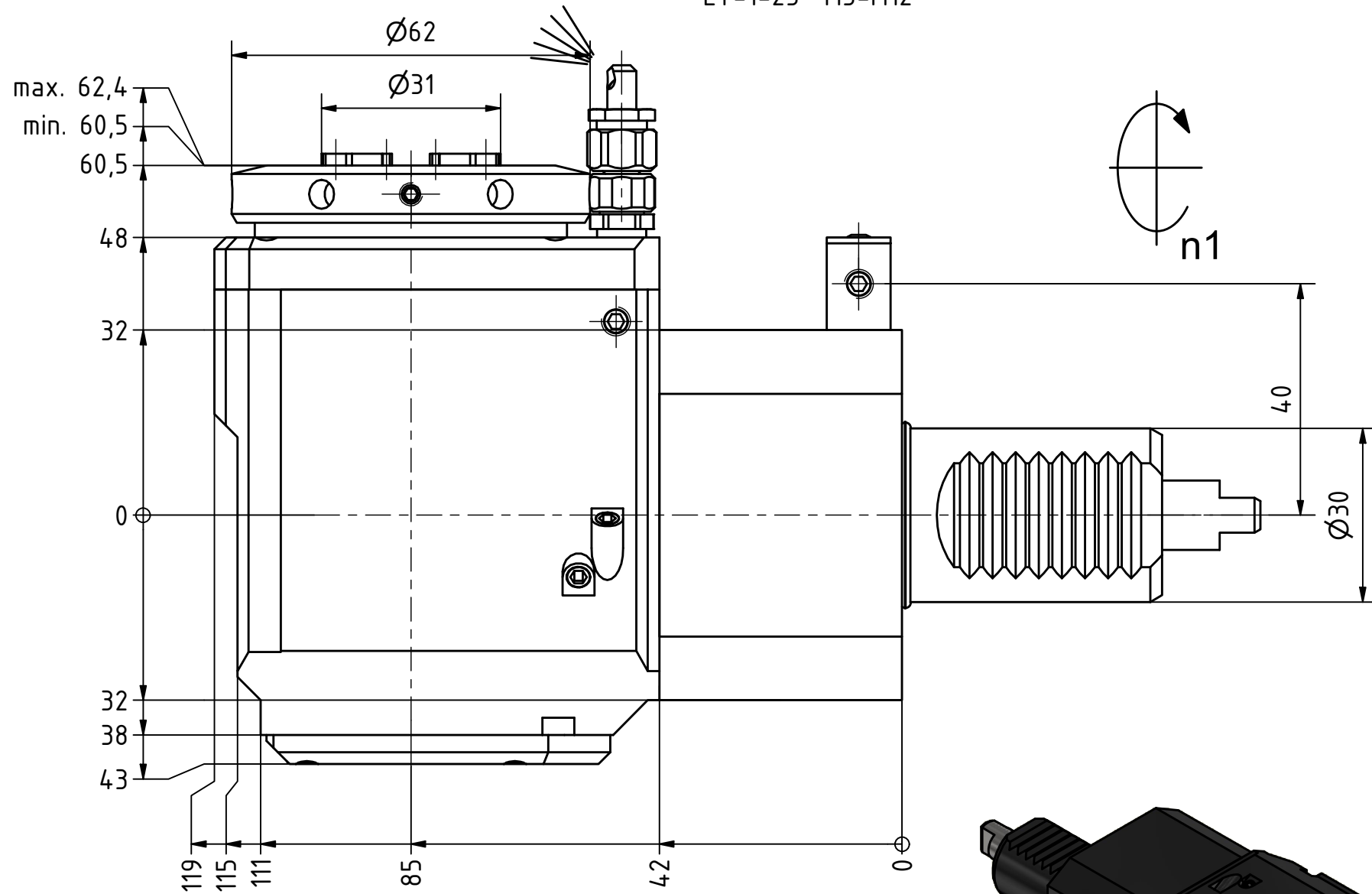

Spannzangenschlüssel für
innenliegende Mutter
*Clamping wrench for
internal collet*
225AX

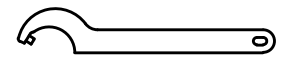

Hakenschlüssel
mit Zapfen
*Hook wrench
with fixed pin*
DIN1810 B 58x62

Copyright **EWS Tool Technologies**
 Weitergabe und Vervielfältigung dieser Unterlage,
 Verwertung und Mitteilung ihres Inhalts nicht
 gestattet, soweit nicht ausdrücklich zugestanden.
 Zuwiderhandlungen verpflichten zu Schadenersatz.

Bemerkung - Note

Technische Daten - technical data

Weight	= 4.125 [kg]
Torque max. (M1/M2)	= 32 / 32 [Nm]
Speed max. (n1/n2)	= 8000 / 8000 [1/min]
Gear ratio (i)=n1:n2	= 1:1

Benennung - Title

Radial Bohr und Fräskopf
Radial drilling and milling head

EWS Tool Technologies
 EWS Weigele GmbH & Co. KG
 Maybachstr. 1
 D-73066 Utingen
 www.ews-tools.de

Nr. - No.
60.30251809LIMX85

Technische Änderungen vorbehalten!
 Subject to technical modifications!

IDENT: DEWS244382

REV: -/A

MNR.
228712

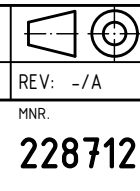

QR