

Spannzange / collet ER32 DIN6499
Spannbereich / clamping range: 2,0 - 20,0

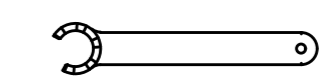

Spannzangenschlüssel für innenliegende Mutter
Clamping wrench for internal collet
232AX

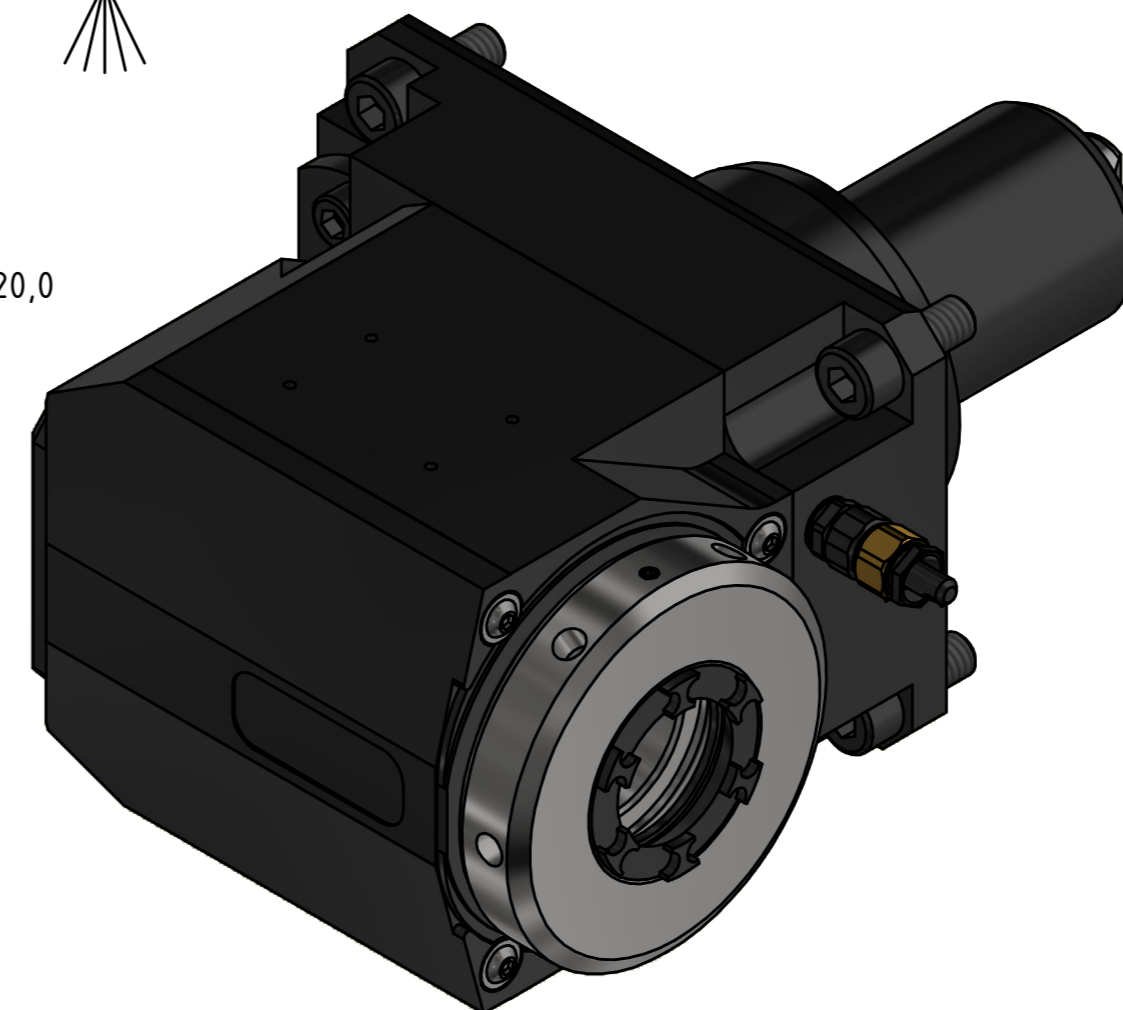
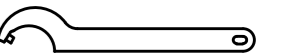

Hakenschlüssel mit Zapfen
Hook wrench with fixed pin
DIN1810 B 68x75
232AX

Copyright EWS Tool Technologies
Weitergabe und Vervielfältigung dieser Unterlage, Verwertung und Mitteilung ihres Inhalts nicht gestattet, soweit nicht ausdrücklich zugestanden. Zuwiderhandlungen verpflichten zu Schadenersatz.

Bemerkung - Note 	Technische Daten - technical data Weight = 7.863 [kg] Torque max. (M1/M2) = 63 / 63 [Nm] Speed max. (n1/n2) = 12000 / 12000 [1/min] Gear ratio (i)=n1:n2 = 1:1	Benennung - Title Radial Bohr und Fräskopf Radial drilling and milling head	 EWS Weigle GmbH & Co. KG Maybachstr. 1 D-73066 Ulm/ingen www.ews-tool.de Nr. - No. 60.6832QSMBMTIMHSD12	Technische Änderungen vorbehalten! Subject to technical modifications! IDENT: DEWS243882 MNR. REV: -/A 228671	 QR
----------------------	--	---	---	---	---------------