

Spannzange / collet ER32 DIN6499  
Spannbereich / clamping range: 2,0 - 20,0

Gewindebohrzange / tapping collet  
ET-1-32 M5-M12

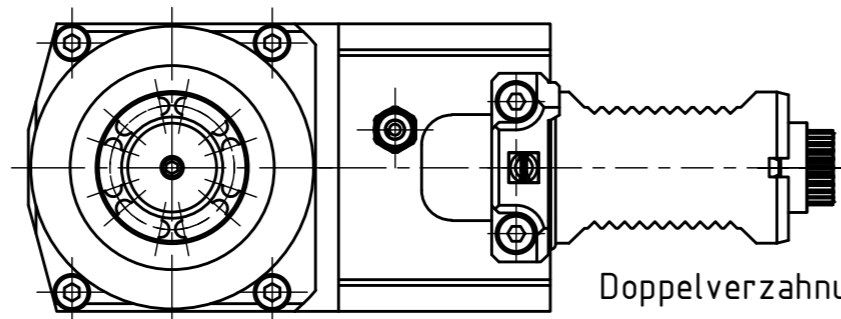

Doppelverzahnung Lizenz Traub  
double tooth system licence Traub

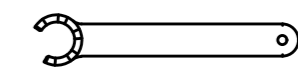
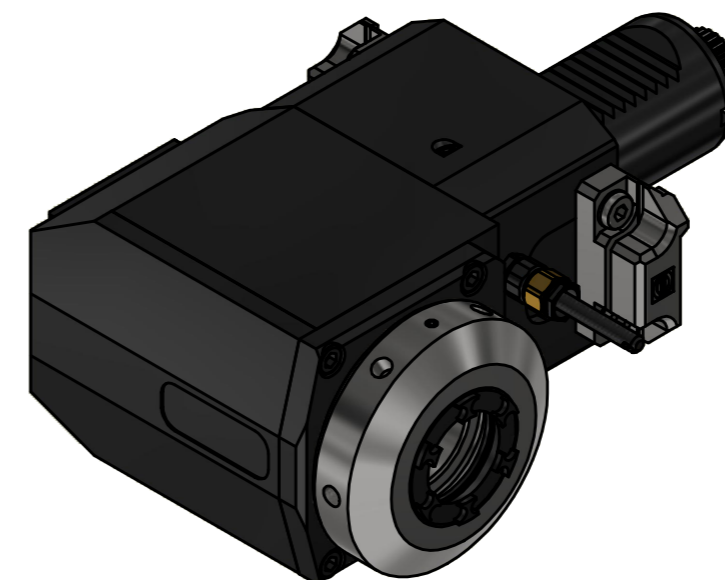

Spannzangenschlüssel für  
innenliegende Mutter  
Clamping wrench for  
internal collet  
232AX

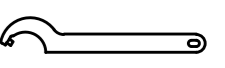

Hakenschlüssel  
mit Zapfen  
Hook wrench  
with fixed pin  
DIN1810 B 68x75

Copyright EWS Tool Technologies  
Weitergabe und Vervielfältigung dieser Unterlage,  
Verwertung und Mitteilung ihres Inhalts nicht  
gestattet, soweit nicht ausdrücklich zugestanden.  
Zuwerhandlungen verpflichten zu Schadenersatz.

Bemerkung - Note

Technische Daten - technical data

Weight = 6.965 [kg]  
Torque max. (M1/M2) = 50 / 25 [Nm]  
Speed max. (n1/n2) = 6000 / 12000 [1/min]  
Gear ratio (i)=n1:n2 = 1:2

Benennung - Title

Radial Bohr und Fräskopf  
Radial drilling and milling head



EWS Weigle GmbH & Co. KG  
Maybachstr. 1  
D-73066 Ulm/ingen  
www.ews-tools.de

Technische Änderungen vorbehalten!  
Subject to technical modifications!

IDENT: DEWS244070

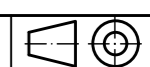

REV: -/A

Nr. - No.  
60.4032CTXRL11FRIM

MNR.  
228649

