

Revolversockel
base of turret

Spannzange / collet ER32 DIN6499
Spannbereich / clamping range: 2,0 - 20,0

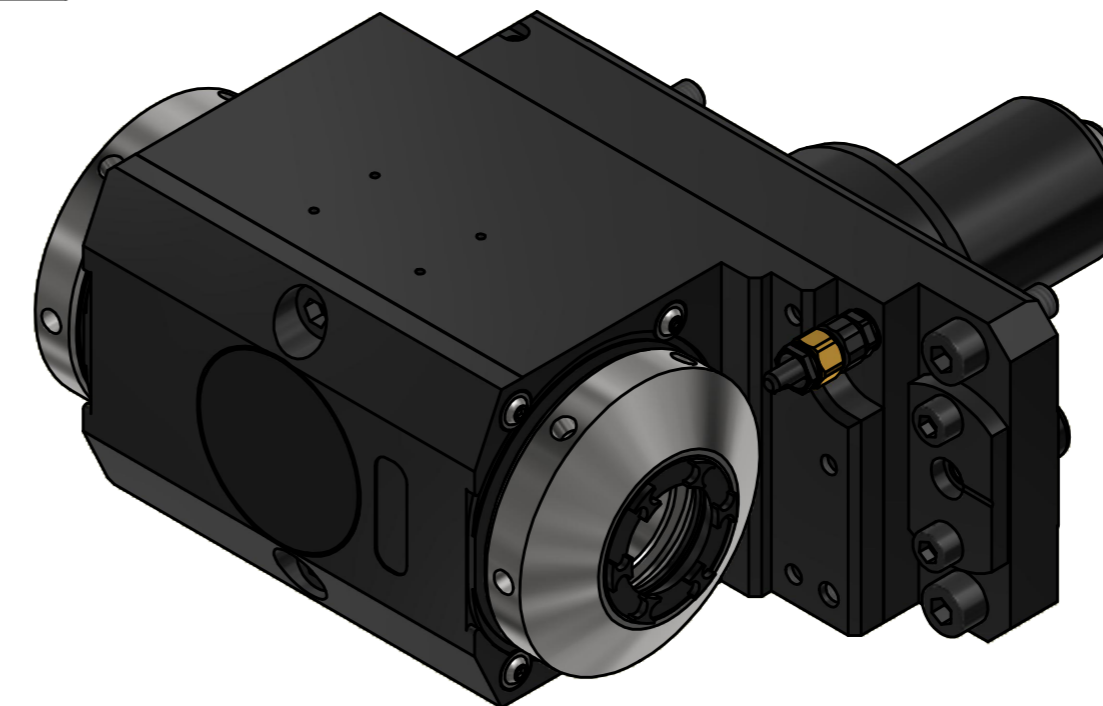

Spannzangenschlüssel für innenliegende Mutter
Clamping wrench for internal collet
232AX

Hakenschlüssel mit Nase
Hook wrench with nose end
DIN1810 A 68x75

Copyright **EWS Tool Technologies**
Weitergabe und Vervielfältigung dieser Unterlage,
Verwertung und Mitteilung ihres Inhalts nicht
gestattet, soweit nicht ausdrücklich zugestanden.
Zuwerhandlungen verpflichten zu Schadenersatz.

Benennung - Title	Technische Daten - technical data
	Weight = 10.686 [kg]
	Torque max. (M1/M2) = 63 / 63 63 [Nm]
	Speed max. (n1/n2) = 6000 / 6000 6000 [1/min]
	Gear ratio (i)=n1:n2 = 1:1

Benennung - Title
Radial Bohr und Fräskopf, zurückges
Radial drill. and mill. head offset

EWS Tool Technologies	EWS Weigle GmbH & Co. KG Maybachstr. 1 D-73066 Ulm/ingen www.ews-tool.de	Technische Änderungen vorbehalten! Subject to technical modifications!	REV: -/B
Nr. - No.	IDENT: DEWS243495	MNR.	
80.6832DQSMGSPBMTIM#01		228590	

