

Spannzange / collet ER32 DIN6499
Spannbereich / clamping range: 2,0 - 20,0

Spannzangenschlüssel für innenliegende Mutter
Clamping wrench for internal collet
232AX

Hakenschlüssel mit Zapfen
Hook wrench with fixed pin
DIN1810 B 68x75

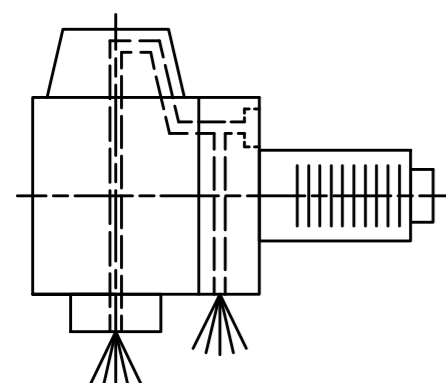

Innen- und Aussenkuehlung / Inside and outside coolant supply
Kuehlmittelfiltrierung+50µ / coolant filtration+50µ

<p>Bemerkung - Note</p> <p>mit Kegelrollenlager with taper roller bearing(s)</p>	<p>Technische Daten - technical data</p> <p>Weight = 8.231 [kg]</p> <p>Torque max. (M1/M2) = 63 / 63 [Nm]</p> <p>Speed max. (n1/n2) = 5000 / 5000 [1/min]</p> <p>Gear ratio (i)=n1:n2 = 1:1</p>	<p>Benennung - Title</p> <p>Radial Bohr und Fräskopf Radial drilling and milling head</p>	<p>EWS Tool Technologies</p> <p>EWS Weigle GmbH & Co. KG Maybachstr. 1 D-73066 Uhlingen www.ews-tool.de</p> <p>Technische Aenderungen vorbehalten! Subject to technical modifications!</p> <p>IDENT: DEWS240767</p> <p>REV: -/A</p> <p>Nr. - No. MNR. 228541</p> <p>60.6832KRQSMBMTIM</p> <p>QR</p>
--	---	---	--

Copyright **EWS Tool Technologies**
Weitergabe und Vervielfaeltigung dieser Unterlage,
Verwertung und Mitteilung ihres Inhalts nicht
gestattet, soweit nicht ausdrecklich zugestanden.
Zuwoerhandlungen verpflichten zu Schadenersatz.