

Spannzange / collet ER32 DIN6499  
Spannbereich / clamping range: 2,0 - 20,0

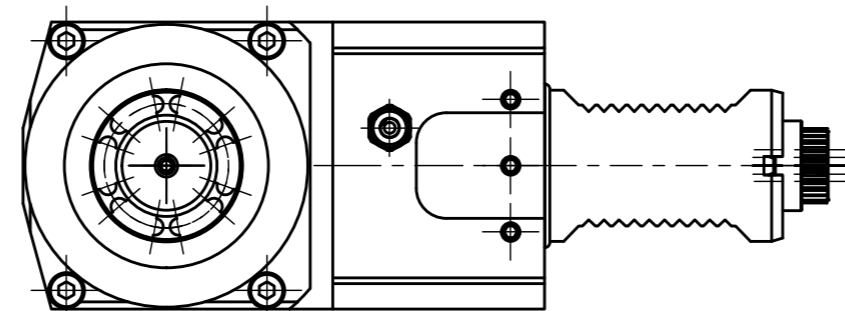

Doppelverzahnung Lizenz Traub  
double tooth system licence Traub

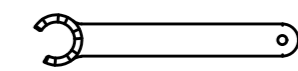
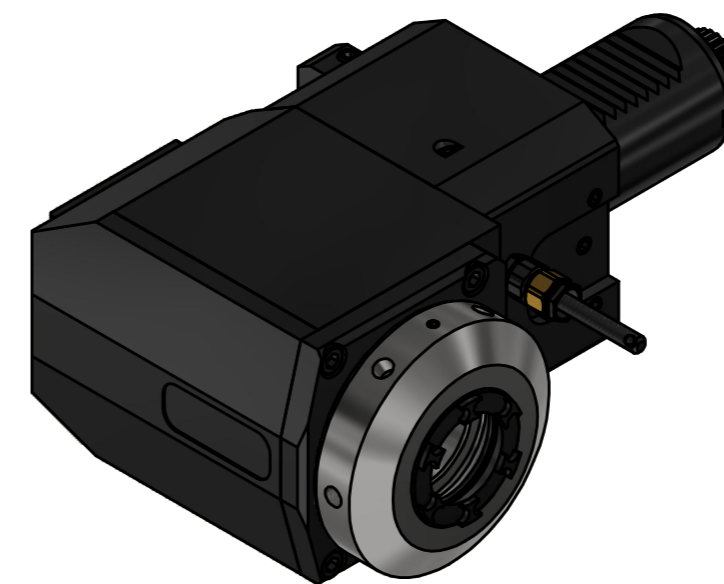

Spannzangenschlüssel für innenliegende Mutter  
Clamping wrench for internal collet  
232AX

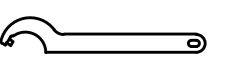

Hakenschlüssel mit Zapfen  
Hook wrench with fixed pin  
DIN1810 B 68x75

Copyright EWS Tool Technologies  
Weitergabe und Vervielfältigung dieser Unterlage, Verwertung und Mitteilung ihres Inhalts nicht gestattet, soweit nicht ausdrücklich zugestanden. Zuwiderhandlungen verpflichten zu Schadenersatz.

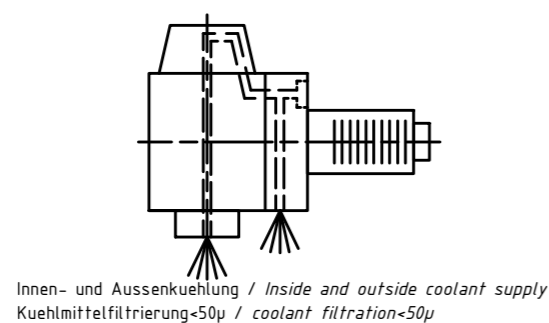

Bemerkung - Note Für Trockenlauf geeignet! Use without coolant fluid allowed!	Technische Daten - technical data
	Weight = 6.956 [kg]
	Torque max. (M1/M2) = 50 / 25 [Nm]
	Speed max. (n1/n2) = 6000 / 12000 [1/min]
	Gear ratio (i)=n1:n2 = 1:2
Pressure (pmax) = 70 [bar]	

Benennung - Title  
**Radial Bohr und Fräskopf**  
**Radial drilling and milling head**

	EWS Weigle GmbH & Co. KG Maybachstr. 1 D-73066 Uhlingen www.ews-tools.de	Technische Änderungen vorbehalten! Subject to technical modifications! IDENT: DEWS243438	
	Nr. - No. <b>60.4032CTXRLIKD11M</b>	REV: -/A MNR. <b>228513</b>	<b>QR</b>