

Spannzange / collet ER25 DIN6499
Spannbereich / clamping range: 1,0 - 16,0

Gewindebohrzange / tapping collet
ET-1-25 M3-M12

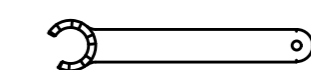

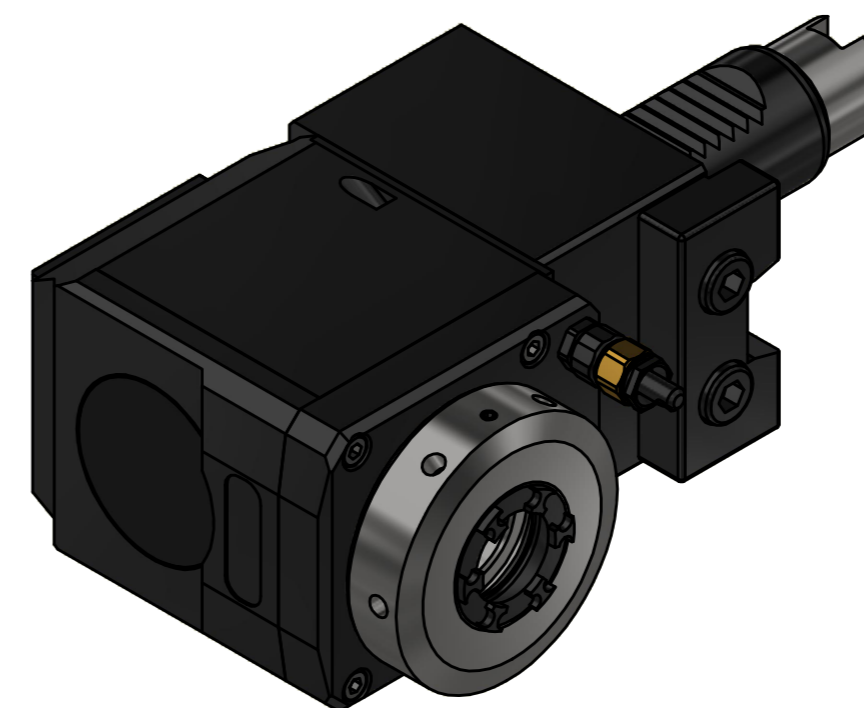
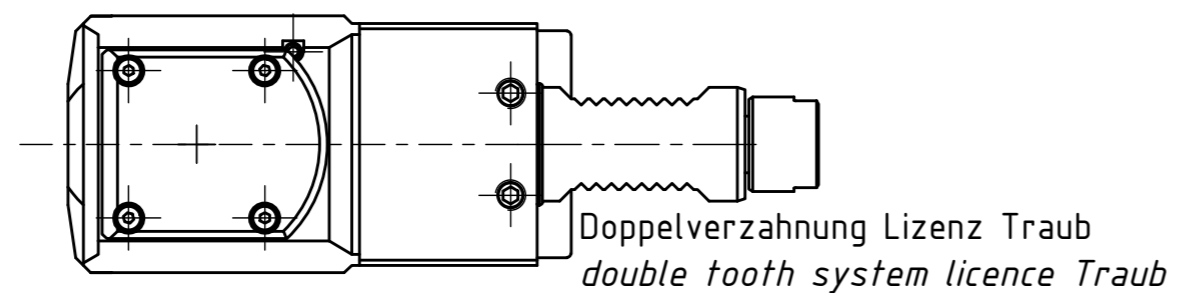
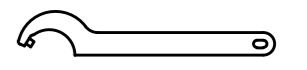

Spannzangenschlüssel für
innenliegende Mutter
Clamping wrench for
internal collet
225AX



Hakenschlüssel
mit Zapfen
Hook wrench
with fixed pin
DIN1810 B 58x62

Copyright **EWS Tool Technologies**
Weitergabe und Vervielfältigung dieser Unterlage,
Verwertung und Mitteilung ihres Inhalts nicht
gestattet, soweit nicht ausdrücklich zugestanden.
Zu widerhandlungen verpflichten zu Schadenersatz.

Bemerkung - Note	Technische Daten - technical data Weight = 4,522 [kg] Torque max. (M1/M2) = 32 / 32 [Nm] Speed max. (n1/n2) = 8000 / 8000 [1/min] Gear ratio (i)=n1:n2 = 1:1	Benennung - Title Radial Bohr und Fräskopf Radial drilling and milling head	 EWS Weigle GmbH & Co. KG Maybachstr. 1 D-73066 Uhlingen www.ews-tool.de	Technische Änderungen vorbehalten! Subject to technical modifications! IDENT: DEWS243263 Nr. - No. MNR. 60.3025G300RLGLVIM	REV: -/A 228507 
------------------	--	---	--	--	---