

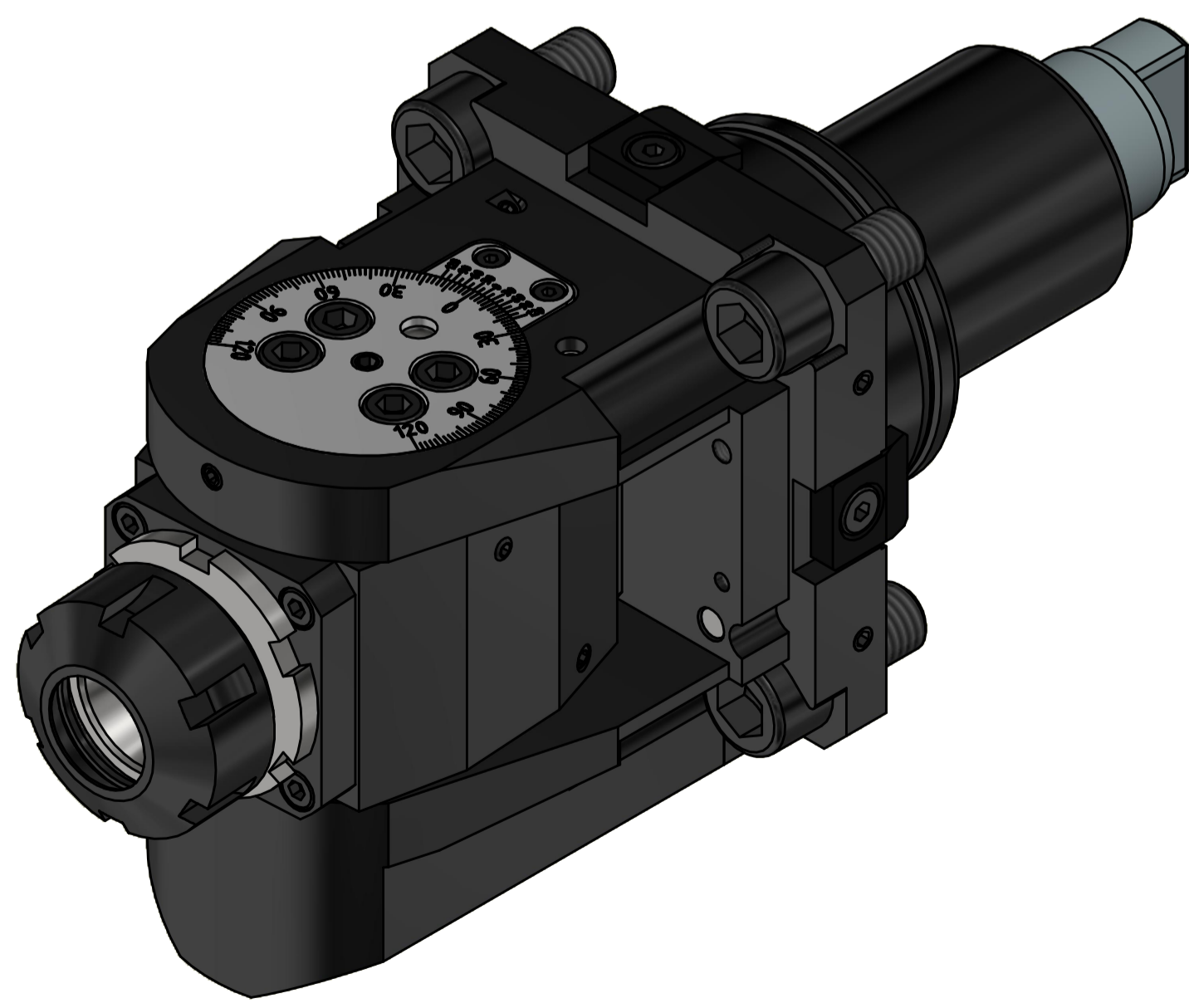

Spannzange / collet ER25 DIN6499
Spannbereich / clamping range: 1,0 - 16,0

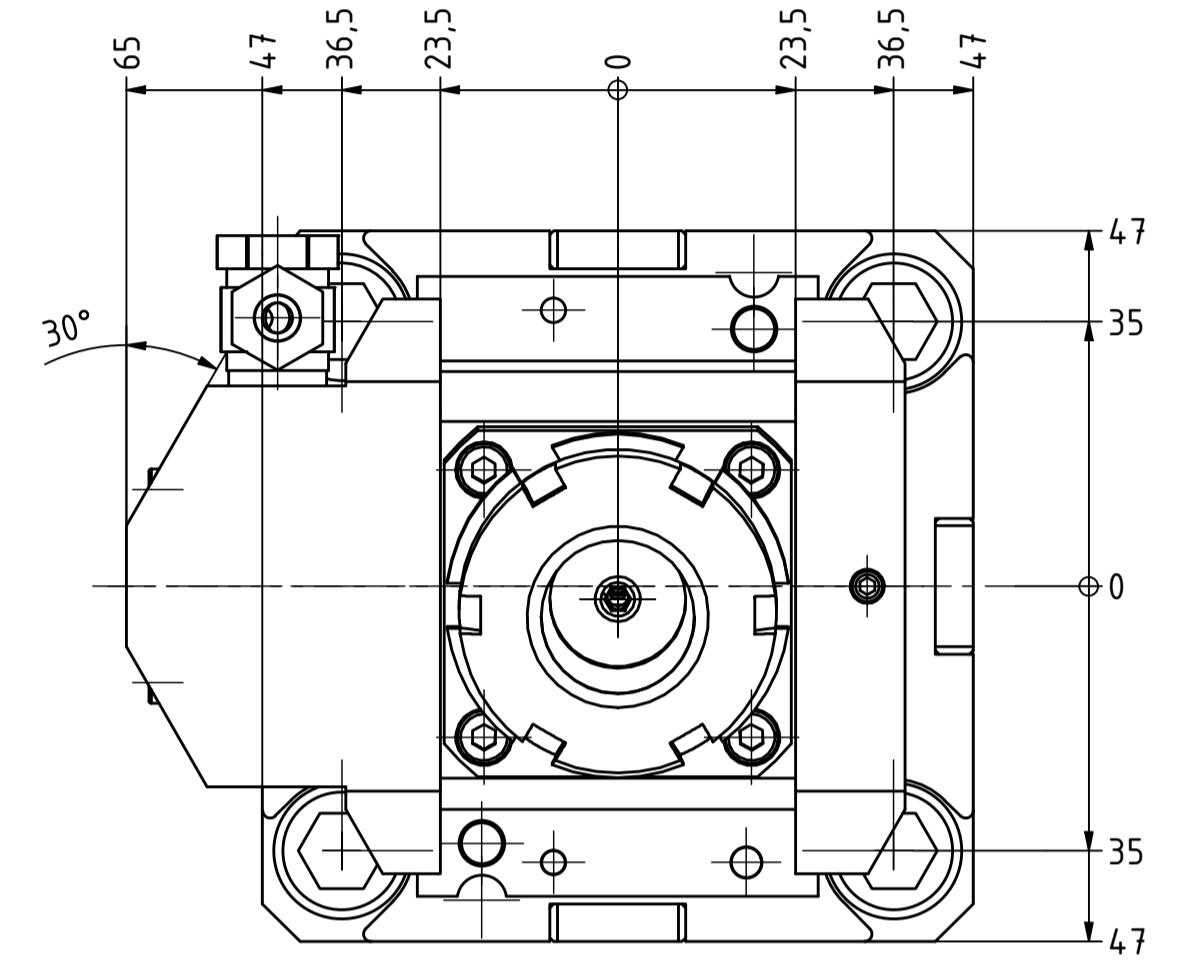

Bitte überprüfen Sie, ob der Werkzeughalter auf ihrem Revolver im Maschinenraum ohne Kollision durchschwenken kann.
Please check the work space of the machine for interferences with the tool holder, especially the swiveling diameter.

Eine Nachbarstation könnte entfallen!
one neighbouring position may be lost!



Hakenschlüssel
mit Nase
Hook wrench with
nose end
DIN1810 A 45x50



Spannzangenschlüssel
Clamping wrench
225

Copyright EWS Tool Technologies
Weitergabe und Vervielfältigung dieser Unterlage,
Verwertung und Mitteilung ihres Inhalts nicht
gestattet, soweit nicht ausdrücklich zugestanden.
Zuwendungen verpflichten zu Schadenersatz.

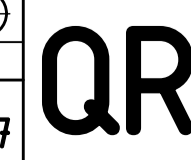
<p><i>Bemerkung - Note</i> Für Trockenlauf geeignet! Use without coolant fluid allowed!</p>	<p><i>Technische Daten - technical data</i> Weight = 5,479 [kg] Torque max. (M1/M2) = 20 / 20 [Nm] Speed max. (n1/n2) = 6000 / 6000 [1/min] Gear ratio (i)=n1:n2 = 1:1 Pressure (pmax) = 70 [bar]</p>	<p><i>Benennung - Title</i> Schwenkkopf Swivel head</p>	<p>EWS Werkzeug-Genossenschaft & Co. KG Hauptstraße 1 63700 Seligen www.ews-tool.de Technische Änderungen vorbehalten! Subject to technical modifications! IDENT: DEWS242148 REV: -/B</p>	<p>NR. - NO. HNR. 63.6525VL6IKD-3.577° 228397</p> 
---	---	---	--	---