

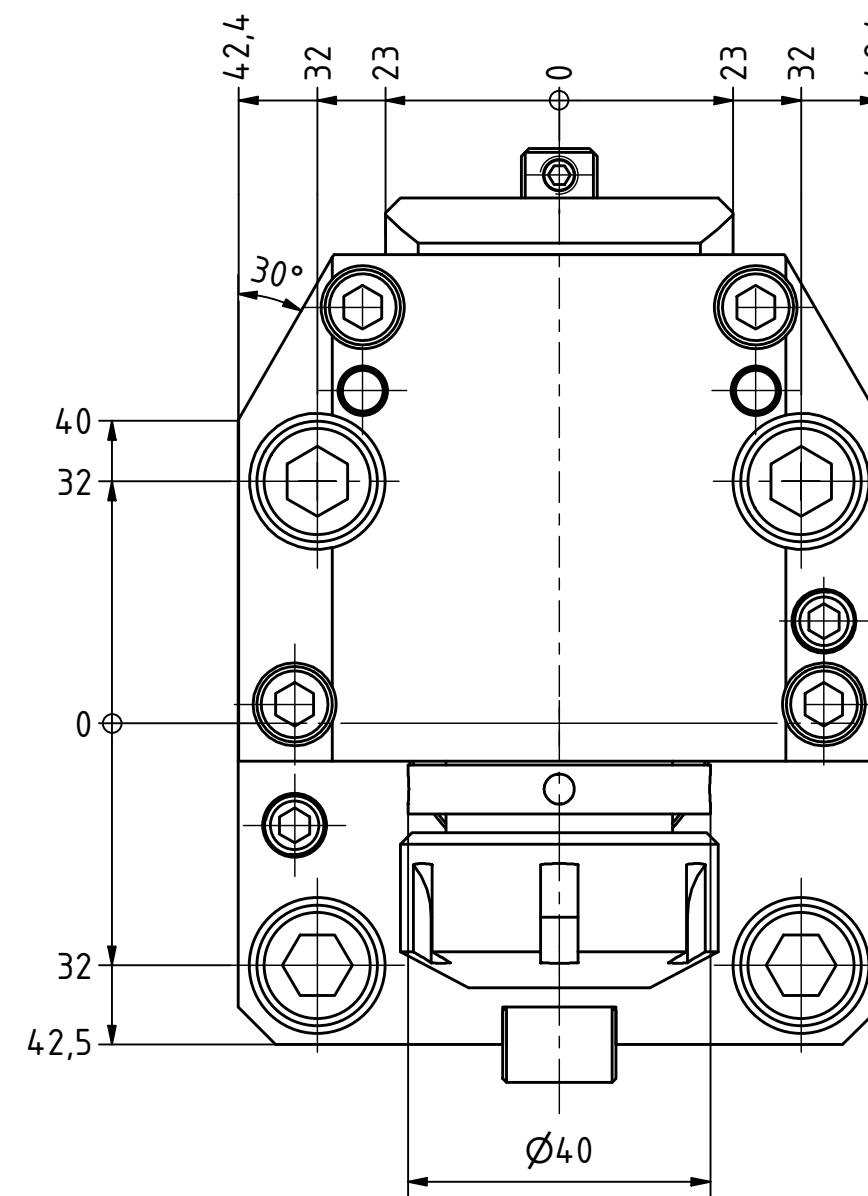

Ceramic Seal

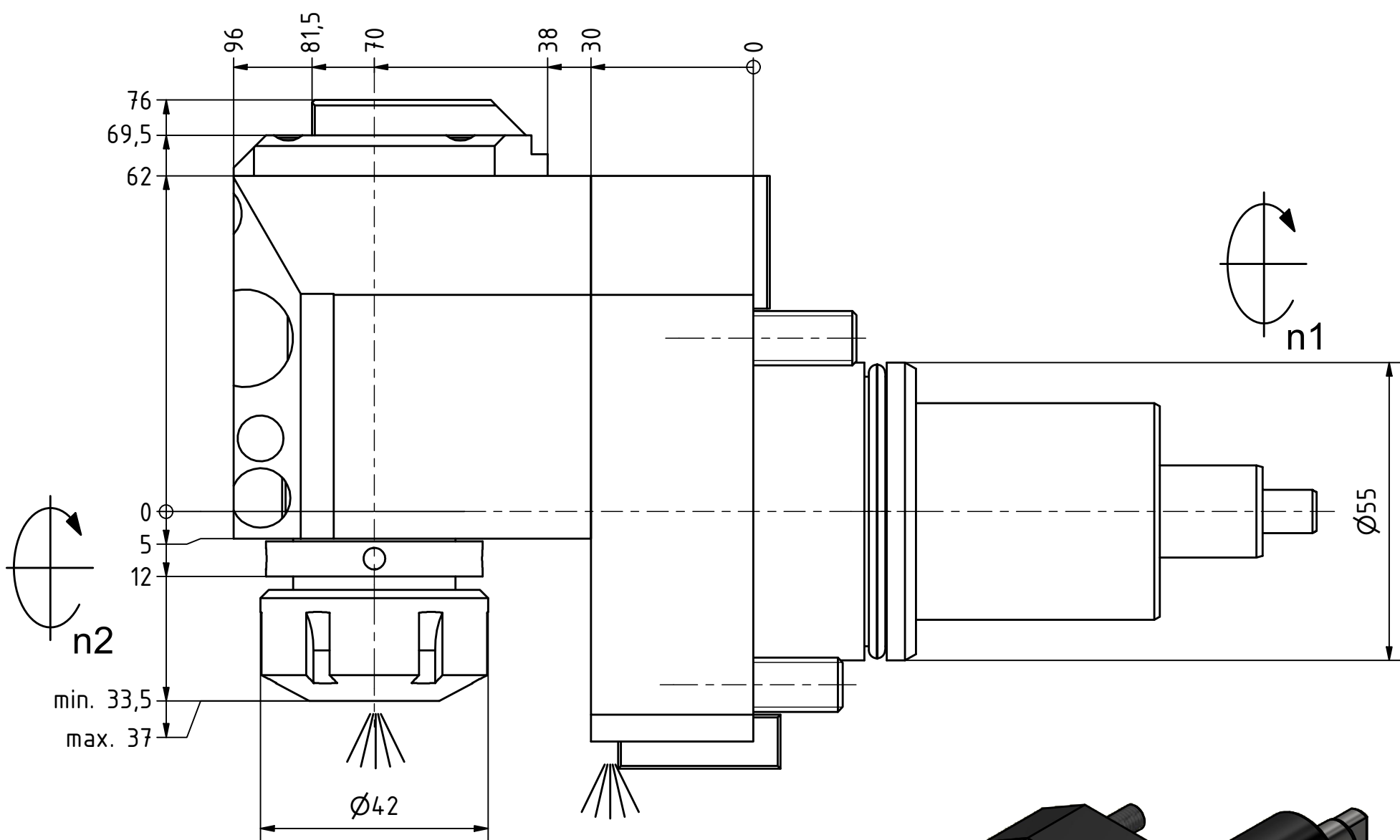

Tech Details



Spannzange / collet ER25 DIN6499  
 Spannbereich / clamping range: 1,0 - 16,0

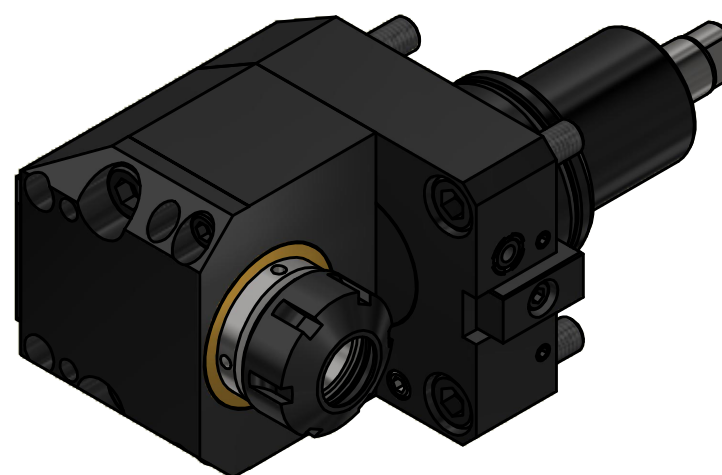
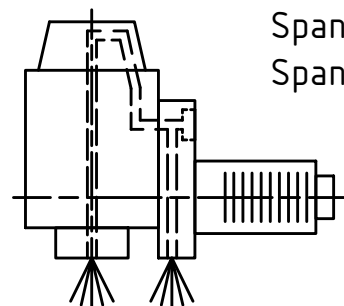

Hakenschlüssel  
 mit Zapfen  
 Hook wrench  
 with fixed pin  
 DIN1810 B 40x42

Spannzangenschlüssel  
 Clamping wrench  
 225

Copyright **EWS Tool Technologies**  
 Weitergabe und Vervielfaeltigung dieser Unterlage,  
 Verwertung und Mitteilung ihres Inhalts nicht  
 gestattet, soweit nicht ausdrecklich zugestanden.  
 Zuwiderhandlungen verpflichten zu Schadenersatz.

Innen- und Aussenkuehlung / Inside and outside coolant supply  
 Kuehlmittelfiltrierung <math>50\mu</math> / coolant filtration <math>50\mu</math>

Bemerkung - Note  
 Für Trockenlauf geeignet!  
 Use without coolant fluid allowed!

Technische Daten - technical data  
 Weight = 5,394 [kg]  
 Torque max. (M1/M2) = 16 / 16 [Nm]  
 Speed max. (n1/n2) = 6000 / 6000 [1/min]  
 Gear ratio (i)=n1:n2 = 1:1  
 Pressure (pmax) = 70 [bar]

Benennung - Title  
**Radial Bohr und Fräskopf, zurückges**  
**Radial drill. and mill. head offset**

**EWS**  
 Tool Technologies  
 EWS Weigle GmbH & Co. KG  
 Maybachstr. 1  
 D-73066 Uthingen  
 www.ews-tools.de

Technische Aenderungen vorbehalten!  
 Subject to technical modifications!

IDENT: DEWS242676



REV: -/A

Nr. - No.  
**80.55251809N4IKD**

MNR.  
**228449**

