

Spannzange / collet ER25 DIN6499
 Spannbereich / clamping range: 1,0 - 16,0

Gewindebohrzange / tapping collet
 ET-1-25 M3-M10

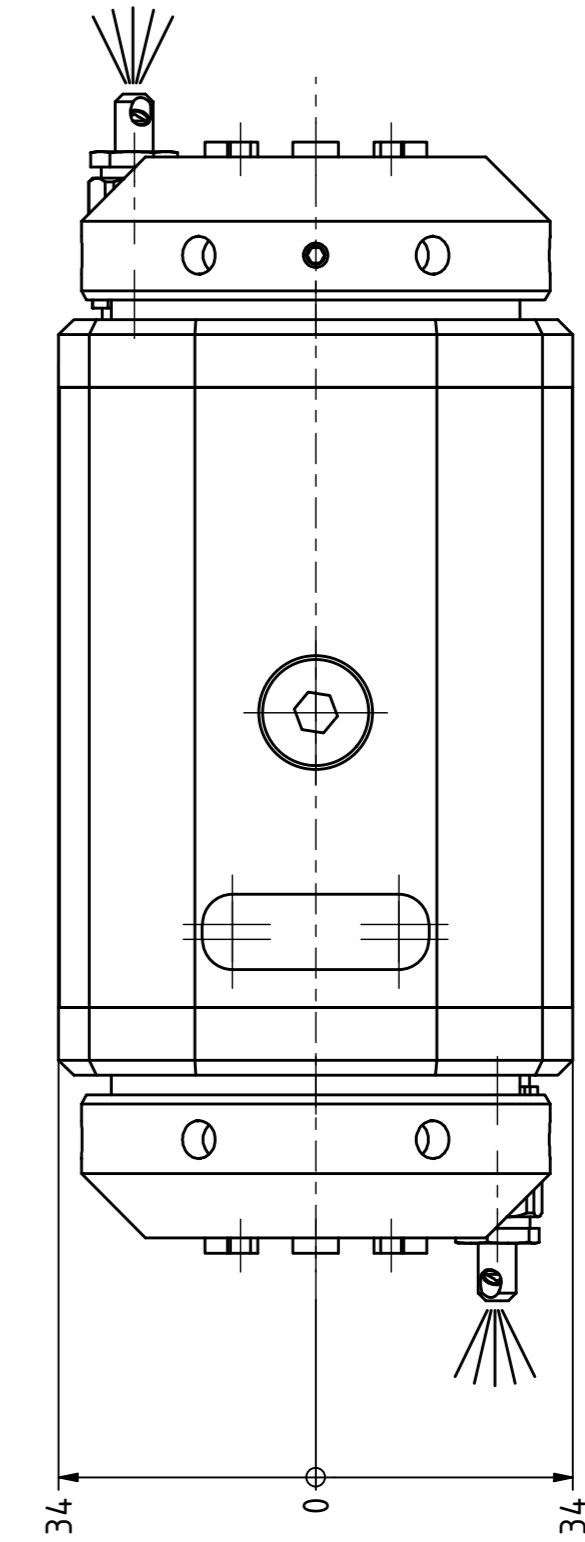
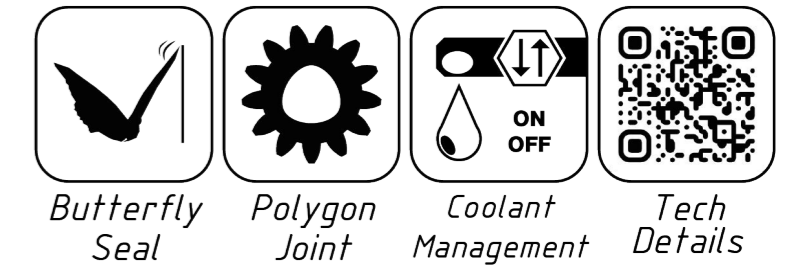
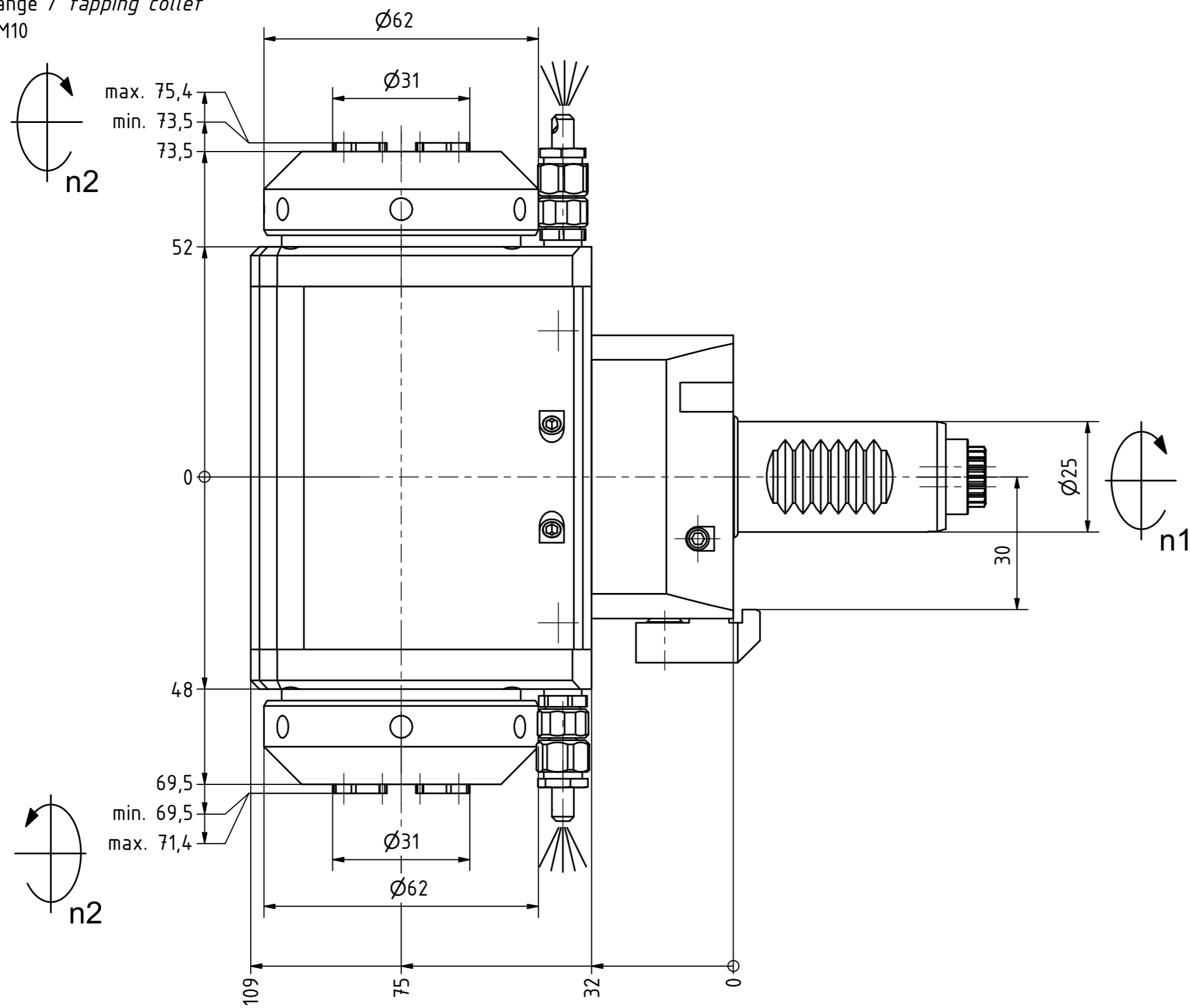

Spannzange / collet ER25 DIN6499
 Spannbereich / clamping range: 1,0 - 16,0

Gewindebohrzange / tapping collet
 ET-1-25 M3-M10

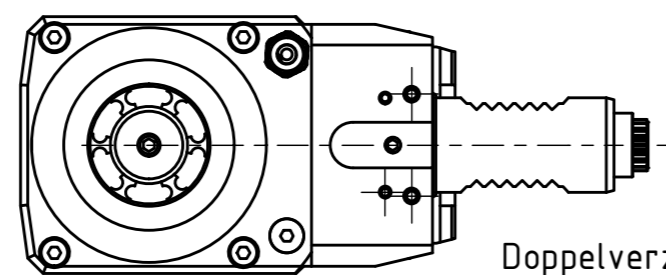

Doppelverzahnung Lizenz Traub
 double tooth system licence Traub

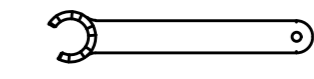
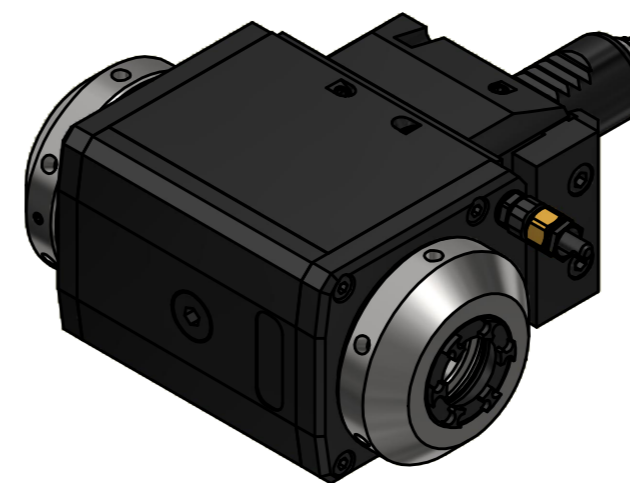

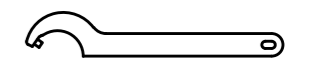

Spannzangenschlüssel für
 innenliegende Mutter
 Clamping wrench for
 internal collet
 225AX



Hakenschlüssel
 mit Zapfen
 Hook wrench
 with fixed pin
 DIN1810 B 58x62

Copyright EWS Tool Technologies
 Weitergabe und Vervielfältigung dieser Unterlage,
 Verwertung und Mitteilung ihres Inhalts nicht
 gestattet, soweit nicht ausdrücklich zugestanden.
 Zuwiderhandlungen verpflichten zu Schadenersatz.

Bemerkung - Note	Technische Daten - technical data Weight = 5,090 [kg] Torque max. (M1/M2) = 25 / 25 25 [Nm] Speed max. (n1/n2) = 8000 / 8000 8000 [1/min] Gear ratio (i)=n1:n2 = 1:1 1:1	Benennung - Title Radial Bohr und Fräskopf Radial drilling and milling head	 EWS Weigle GmbH & Co. KG Maybachstr. 1 D-73066 Ulm/ingen www.ews-tool.de Technische Änderungen vorbehalten! Subject to technical modifications! IDENT: DEWS242044 Nr. - No. 60.2525DE332RLIM MNR. 228361 
------------------	--	---	---