

Spannzange / collet ER25 DIN6499  
 Spannbereich / clamping range: 1,0 - 16,0

Gewindebohrzange / tapping collet  
 ET-1-25 M3-M10

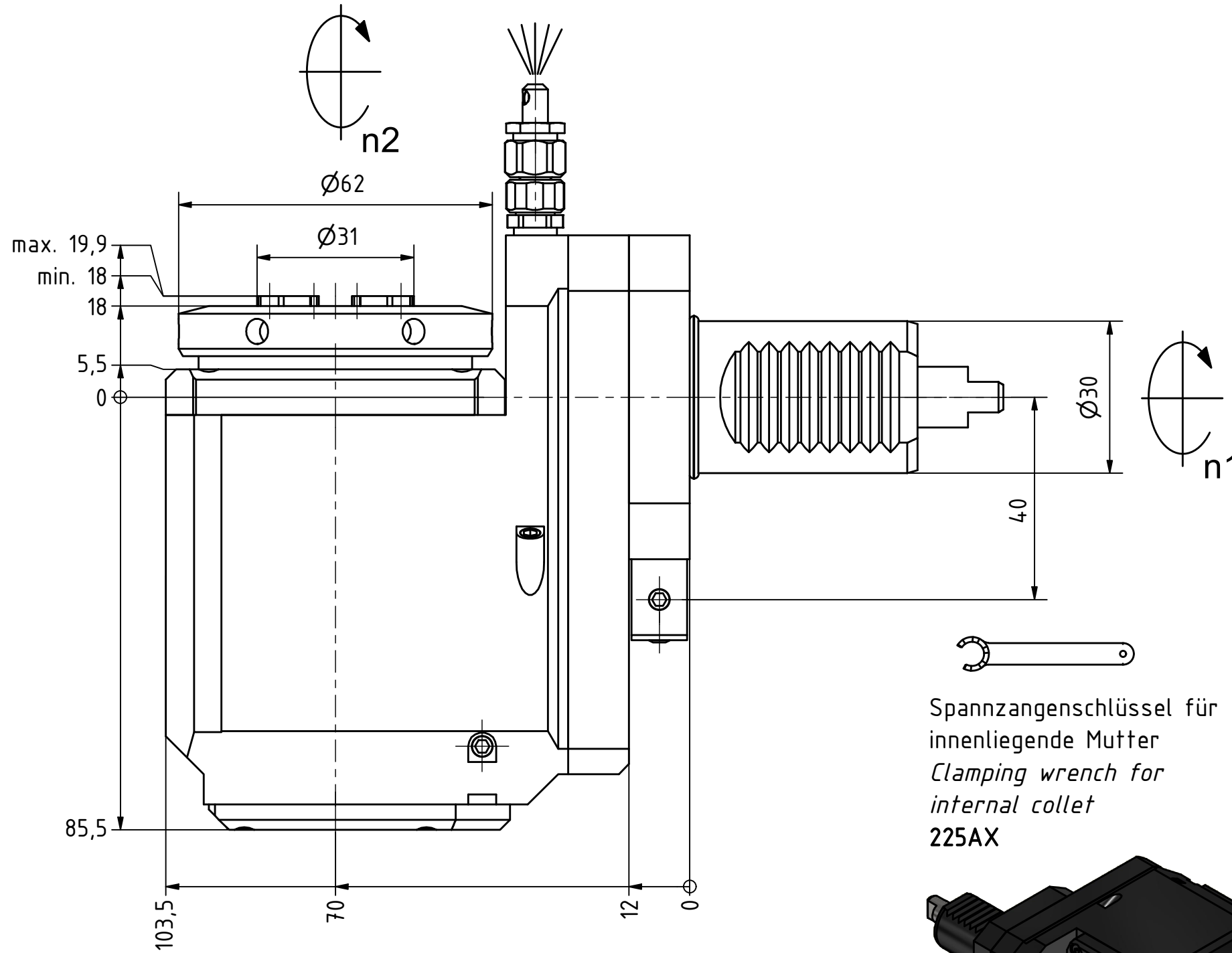
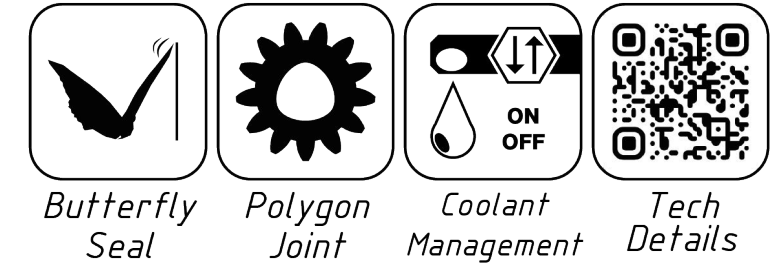

Spannzangenschlüssel für innenliegende Mutter  
*Clamping wrench for internal collet*  
 225AX

Hakenschlüssel mit Zapfen  
*Hook wrench with fixed pin*  
 DIN1810 B 58x62

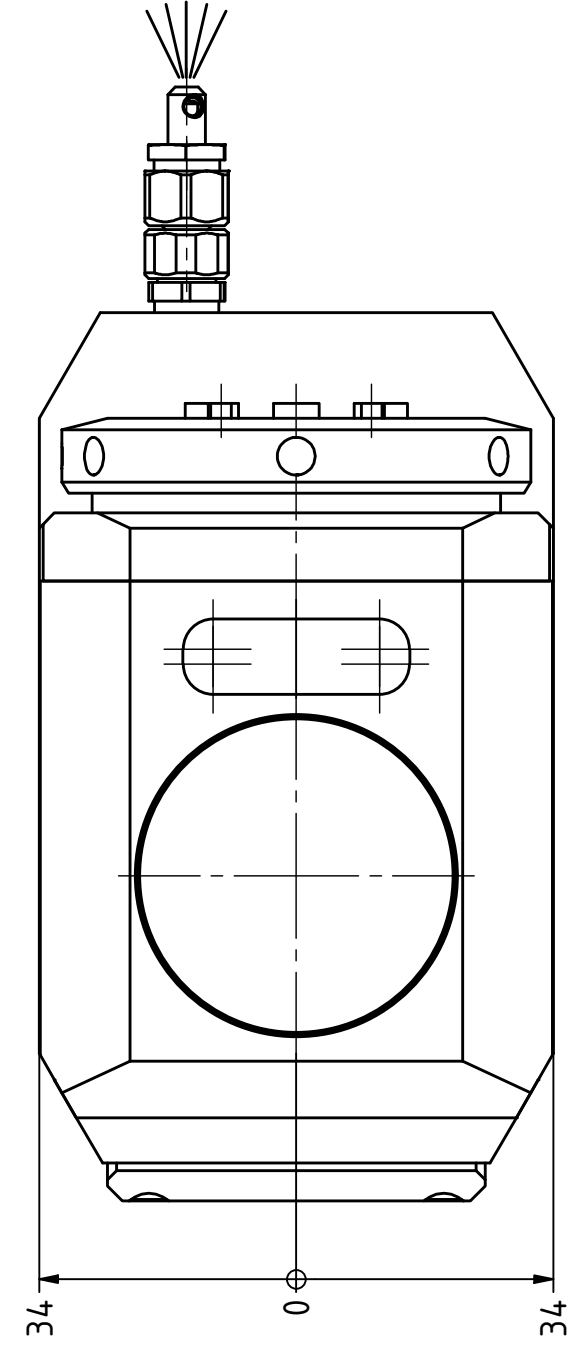
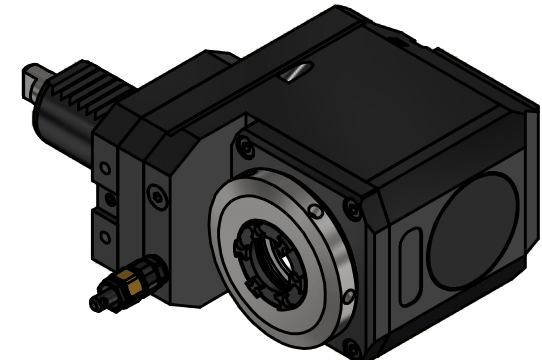

Copyright **EWS Tool Technologies**  
 Weitergabe und Vervielfaeltigung dieser Unterlage,  
 Verwertung und Mitteilung ihres Inhalts nicht  
 gestattet, soweit nicht ausdrecklich zugestanden.  
 Zuwiderhandlungen verpflichten zu Schadenersatz.

Bemerkung - Note	Technische Daten - technical data Weight = 4.223 [kg] Torque max. (M1/M2) = 32 / 32 [Nm] Speed max. (n1/n2) = 8000 / 8000 [1/min] Gear ratio (i)=n1:n2 = 1:1	Benennung - Title <b>Radial Bohr und Fräskopf, zurückges</b> <b>Radial drill. and mill. head offset</b>	 EWS Weigele GmbH & Co. KG Maybachstr. 1 D-73066 Uthingen www.ews-tools.de Nr. - No. <b>80.30251809LIM#01</b>	Technische Aenderungen vorbehalten! Subject to technical modifications! IDENT: DEWS242024 MNR. <b>228360</b>	 <b>QR</b>
------------------	--	---	---	--	---------------