

Spannzange / collet ER32 DIN6499  
Spannbereich / clamping range: 2,0 - 20,0

Gewindebohrzange / tapping collet  
ET-1-32 M5-M12

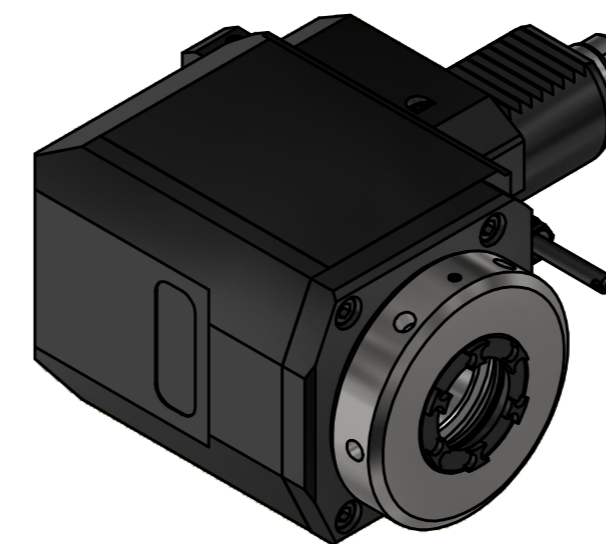

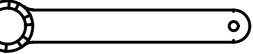

Hakenschlüssel  
mit Zapfen  
Hook wrench  
with fixed pin  
DIN1810 B 68x75



Spannzangenschlüssel für  
innenliegende Mutter  
Clamping wrench for  
internal collet  
232AX

Copyright **EWS Tool Technologies**  
Weitergabe und Vervielfältigung dieser Unterlage,  
Verwertung und Mitteilung ihres Inhalts nicht  
gestattet, soweit nicht ausdrücklich zugestanden.  
Zuwerhandlungen verpflichten zu Schadenersatz.

Bemerkung - Note	Technische Daten - technical data <b>Weight</b> = 6.281 [kg] <b>Torque max.</b> (M1/M2) = 63 / 63 [Nm] <b>Speed max.</b> (n1/n2) = 6000 / 6000 [1/min] <b>Gear ratio</b> (i)=n1:n2 = 1:1	Benennung - Title <b>Radial Bohr und Fräskopf</b> <b>Radial drilling and milling head</b>	 <b>EWS</b> Weigela GmbH & Co. KG Maybachstr. 1 D-73066 Uhingen www.ews-tools.de Technische Änderungen vorbehalten! Subject to technical modifications! IDENT: DEWS242071 Nr. - No. 60.40321809RGLIM MNR. 228363 REV: -/A	
------------------	--	---	---	---