

Doppelverzahnung Lizenz Traub
double tooth system licence Traub

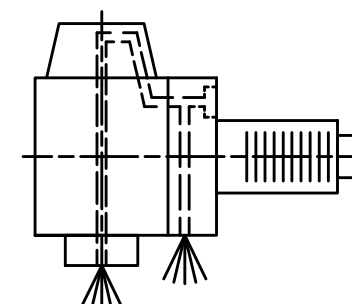
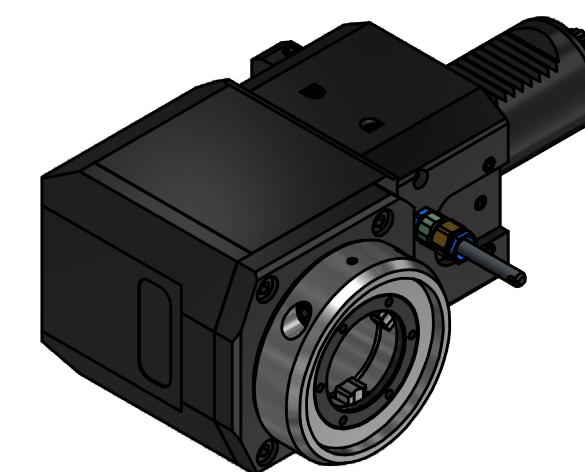

Innen- und Aussenkuehlung / Inside and outside coolant supply
Kuehlmittelfiltrierung=50 μ / coolant filtration=50 μ

Copyright **EWS Tool Technologies**
Weitergabe und Vervielfaeltigung dieser Unterlage,
Verwertung und Mitteilung ihres Inhalts nicht
gestattet, soweit nicht ausdrecklich zugestanden.
Zuwiderhandlungen verpflichten zu Schadenersatz.

<p>Bemerkung - Note Für Trockenlauf geeignet! Use without coolant fluid allowed! mit Kegelrollenlager with taper roller bearing(s)</p>	<p>Technische Daten - technical data Weight = 7.160 [kg] Torque max. (M1/M2) = 40 / 80 [Nm] Speed max. (n1/n2) = 8000 / 4000 [1/min] Gear ratio (i)=n1:n2 = 2:1 Pressure (pmax) = 70 [bar]</p>	<p>Benennung - Title Radial Bohr und Fräskopf Radial drilling and milling head</p>	<table border="1"> <tr> <td data-bbox="2226 1915 2463 1974"> </td> <td data-bbox="2463 1915 2908 1974"> <p>Technische Aenderungen vorbehalten! Subject to technical modifications!</p> </td> </tr> <tr> <td data-bbox="2226 1974 2463 2045"> <p>Nr. - No. 60.40VX4KRCTXRLIKD12#01</p> </td> <td data-bbox="2463 1974 2908 2045"> <p>IDENT: DEWS241001 REV: -/A MNR. 228231</p> </td> </tr> </table>		<p>Technische Aenderungen vorbehalten! Subject to technical modifications!</p>	<p>Nr. - No. 60.40VX4KRCTXRLIKD12#01</p>	<p>IDENT: DEWS241001 REV: -/A MNR. 228231</p>
	<p>Technische Aenderungen vorbehalten! Subject to technical modifications!</p>						
<p>Nr. - No. 60.40VX4KRCTXRLIKD12#01</p>	<p>IDENT: DEWS241001 REV: -/A MNR. 228231</p>						

