

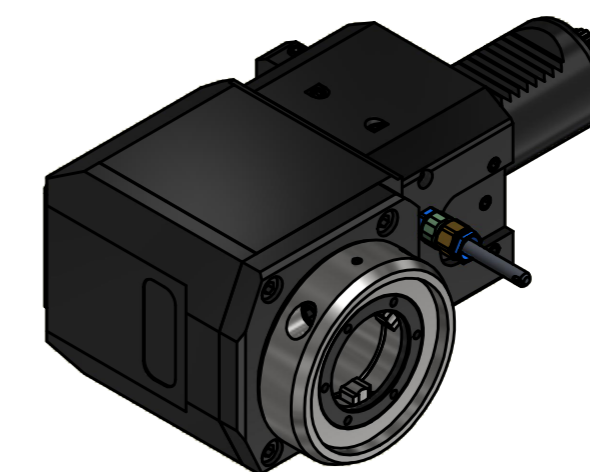

Doppelverzahnung Lizenz Traub  
double tooth system licence Traub



Copyright **EWS Tool Technologies**  
Weitergabe und Vervielfältigung dieser Unterlage,  
Verwertung und Mitteilung ihres Inhalts nicht  
gestattet, soweit nicht ausdrücklich zugestanden.  
Zu widerhandlungen verpflichtet zu Schadenersatz.

Bemerkung - Note  mit Kegelrollenlager with taper roller bearing(s)	Technische Daten - technical data Weight = 7,068 [kg] Torque max. (M1/M2) = 40 / 80 [Nm] Speed max. (n1/n2) = 8000 / 4000 [1/min] Gear ratio (i)=n1:n2 = 2:1	Benennung - Title  <b>Radial Bohr und Fräskopf</b> <b>Radial drilling and milling head</b>	 EWS Weigle GmbH & Co. KG Maybachstr. 1 D-73066 Ulm/ingen www.ews-tool.de Technische Änderungen vorbehalten! Subject to technical modifications! IDENT: DEWS241016 Nr. - No. 60.40VX4KRCTXRLI2#01 MNR. 228227 REV: -/A	
--	--	---	--	---