

Doppelverzahnung Lizenz Traub
double tooth system licence Traub

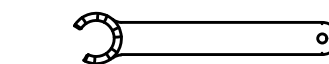

Spannzangenschlüssel für innenliegende Mutter
Clamping wrench for internal collet
225AX

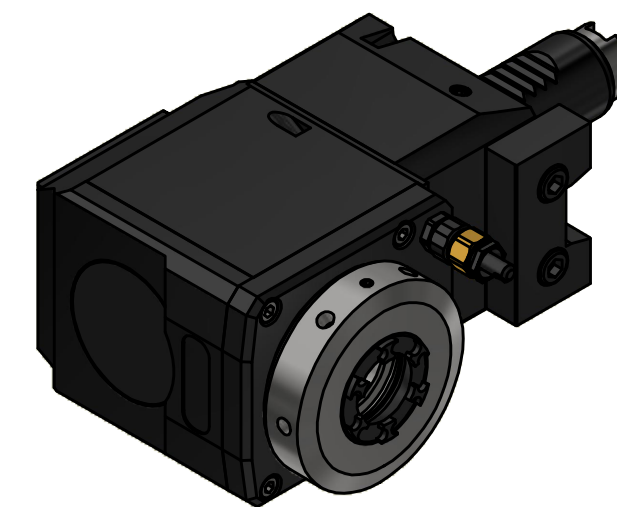
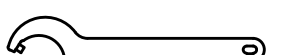

Hakenschlüssel mit Zapfen
Hook wrench with fixed pin
DIN1810 B 58x62

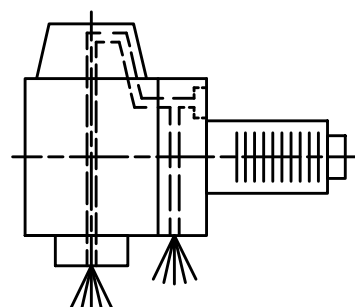

Innen- und Aussenkuehlung / Inside and outside coolant supply
Kuehlmittelfiltrierung=50µ / coolant filtration=50µ

Copyright **EWS Tool Technologies**
Weitergabe und Vervielfaeltigung dieser Unterlage,
Verwertung und Mitteilung ihres Inhalts nicht
gestattet, soweit nicht ausdrucklich zugestanden.
Zuwaerdigungen verpflichten zu Schadenersatz.

<p>Bemerkung - Note Für Trockenlauf geeignet! Use without coolant fluid allowed!</p>	<p>Technische Daten - technical data Weight = 4,562 [kg] Torque max. (M1/M2) = 24 / 12 [Nm] Speed max. (n1/n2) = 6000 / 12000 [1/min] Gear ratio (i)=n1:n2 = 1:2 Pressure (pmax) = 70 [bar]</p>	<p>Benennung - Title Radial Bohr und Fräskopf Radial drilling and milling head</p>	<p>EWS EWS Weigle GmbH & Co. KG Maybachstr. 1 D-73066 Ulm/ingen www.ews-tool.de</p> <p>Technische Aenderungen vorbehalten! Subject to technical modifications! IDENT: DEWS241531</p> <p>Nr. - No. 60.2525G200RLIKD1VIMX90</p> <p>REV: -/A MNR. 228287</p> <p>QR</p>
--	---	--	---