

Spannzange / collet ER25 DIN6499
Spannbereich / clamping range: 1,0 - 16,0

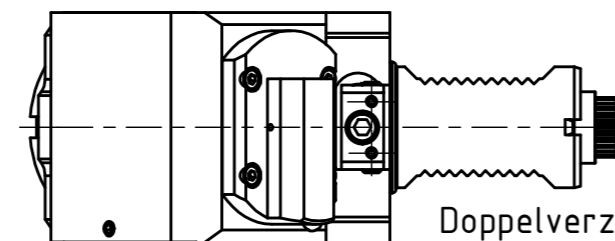

Doppelverzahnung Lizenz Traub
double tooth system licence Traub

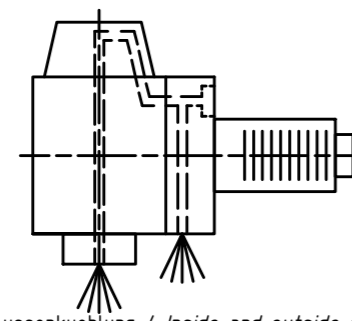

Innen- und Aussenkühlung / inside and outside coolant supply
Kein Trockenlauf / No dry run
Kühlmittelfiltrierung=50µ / coolant filtration=50µ

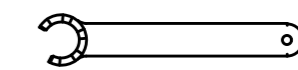
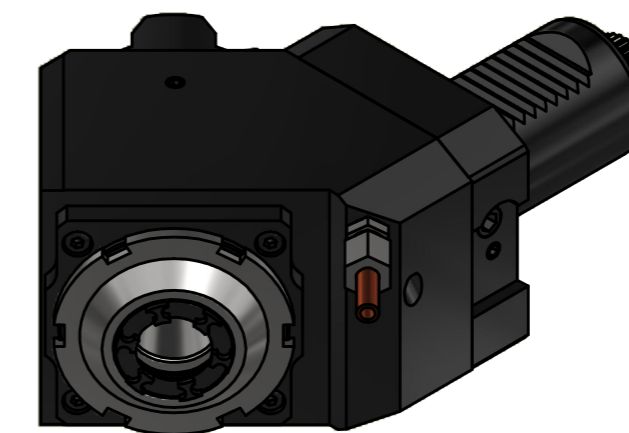

Spannzangenschlüssel für
innenliegende Mutter
Clamping wrench for
internal collet
225AX

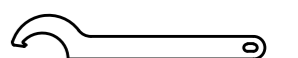

Hakenschlüssel
mit Nase
Hook wrench with
nose end
DIN1810 A 68x75

Copyright EWS Tool Technologies
Weitergabe und Vervielfältigung dieser Unterlage,
Verwertung und Mitteilung ihres Inhalts nicht
gestattet, soweit nicht ausdrücklich zugestanden.
Zuwendungen verpflichten zu Schadenersatz.

<p>Bemerkung - Note Nicht ohne Kuehlmittel betreiben! Not for use without coolant-fluid!</p>	<p>Technische Daten - technical data Weight = 5,095 [kg] Torque max. (M1/M2) = 50 / 25 [Nm] Speed max. (n1/n2) = 6000 / 12000 [1/min] Gear ratio (i)=n1:n2 = 1:2 Pressure (pmax) = 70 [bar]</p>
--	---

Benennung - Title
Radial Bohr und Fräskopf
Radial drilling and milling head

<p>EWS Tool Technologies</p>	<p>EWS Weigle GmbH & Co. KG Maybachstr. 1 D-73066 Uhingen www.ews-tools.de</p>	<p>Technische Aenderungen vorbehalten! Subject to technical modifications! IDENT: DEWS242006</p>	<p>REV: -/A MNR. 227952</p>	<p>QR</p>
<p>Nr. - No. 60.4025CTXRLIK11TKW45IM</p>				