

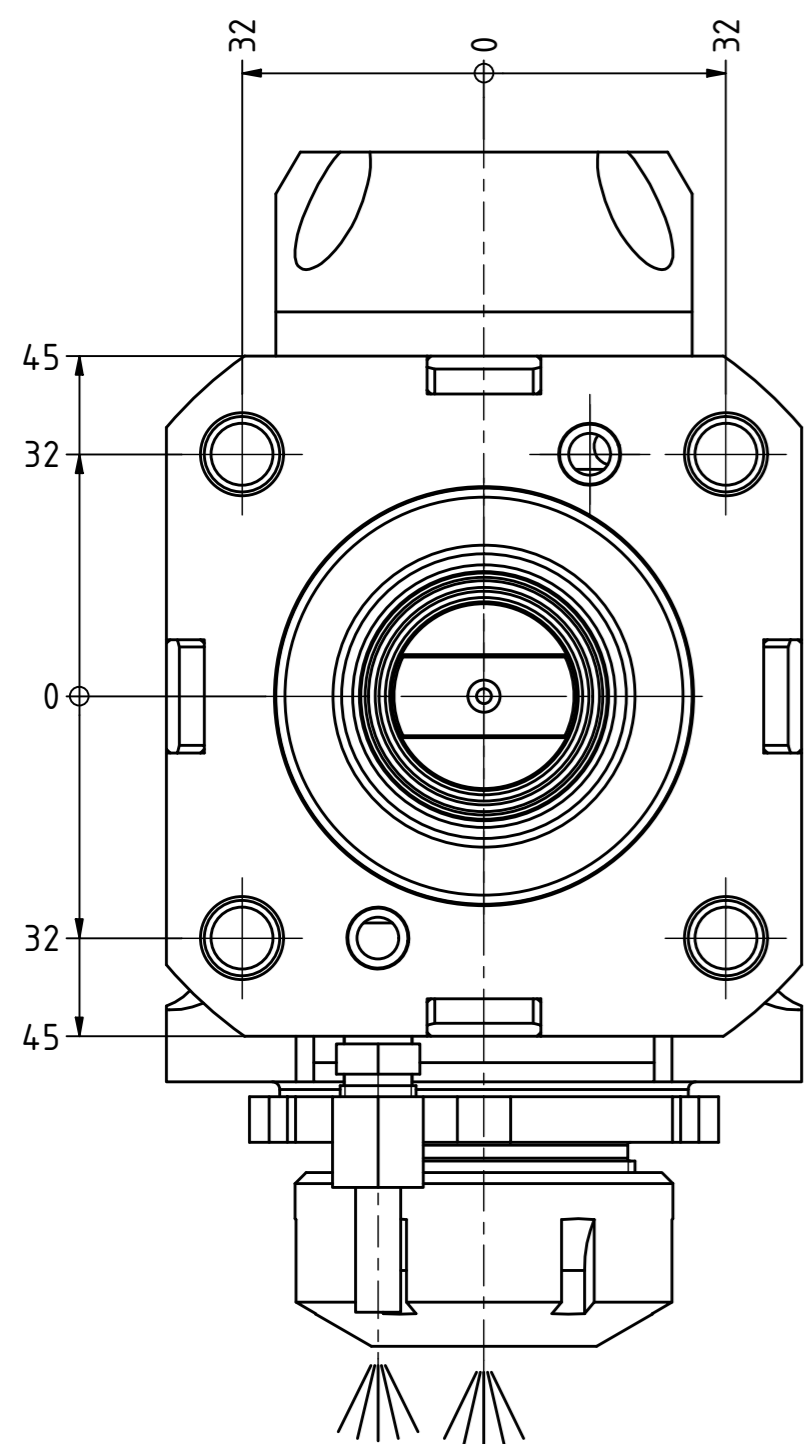

Highspeed



Tech Details



Spannzange / collet ER32 DIN6499
Spannbereich / clamping range: 2,0 - 20,0

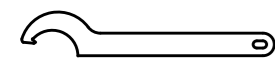
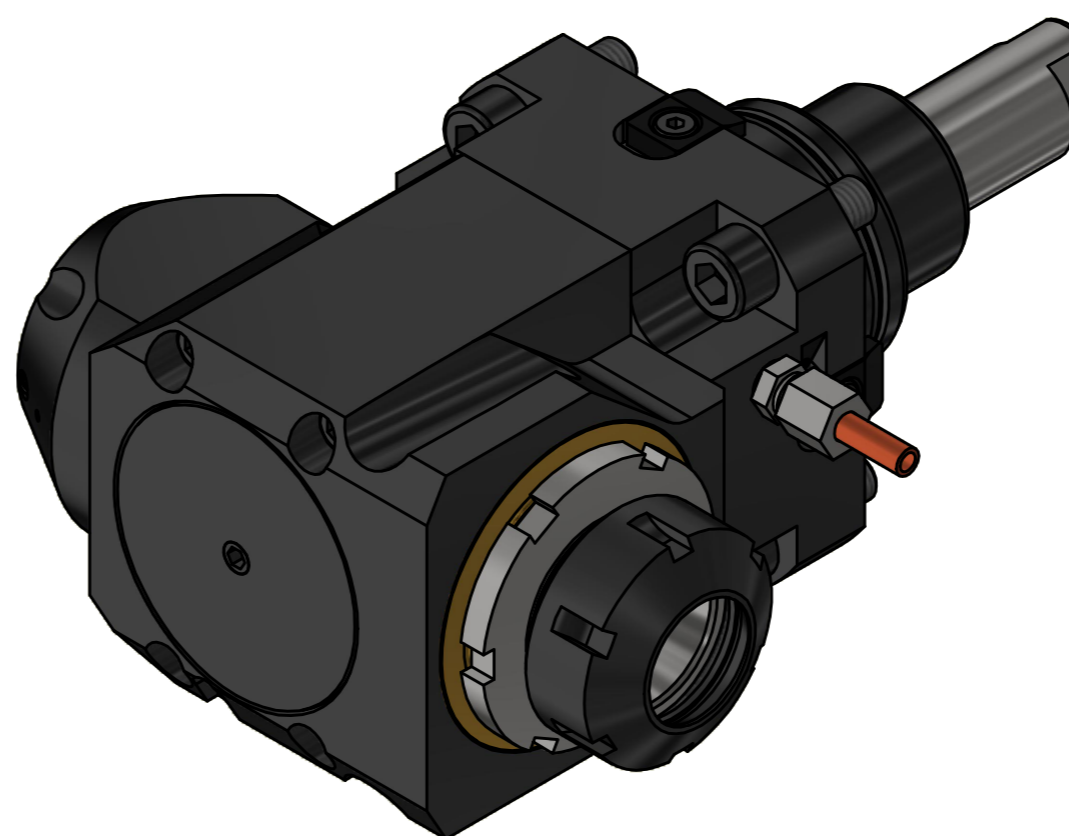
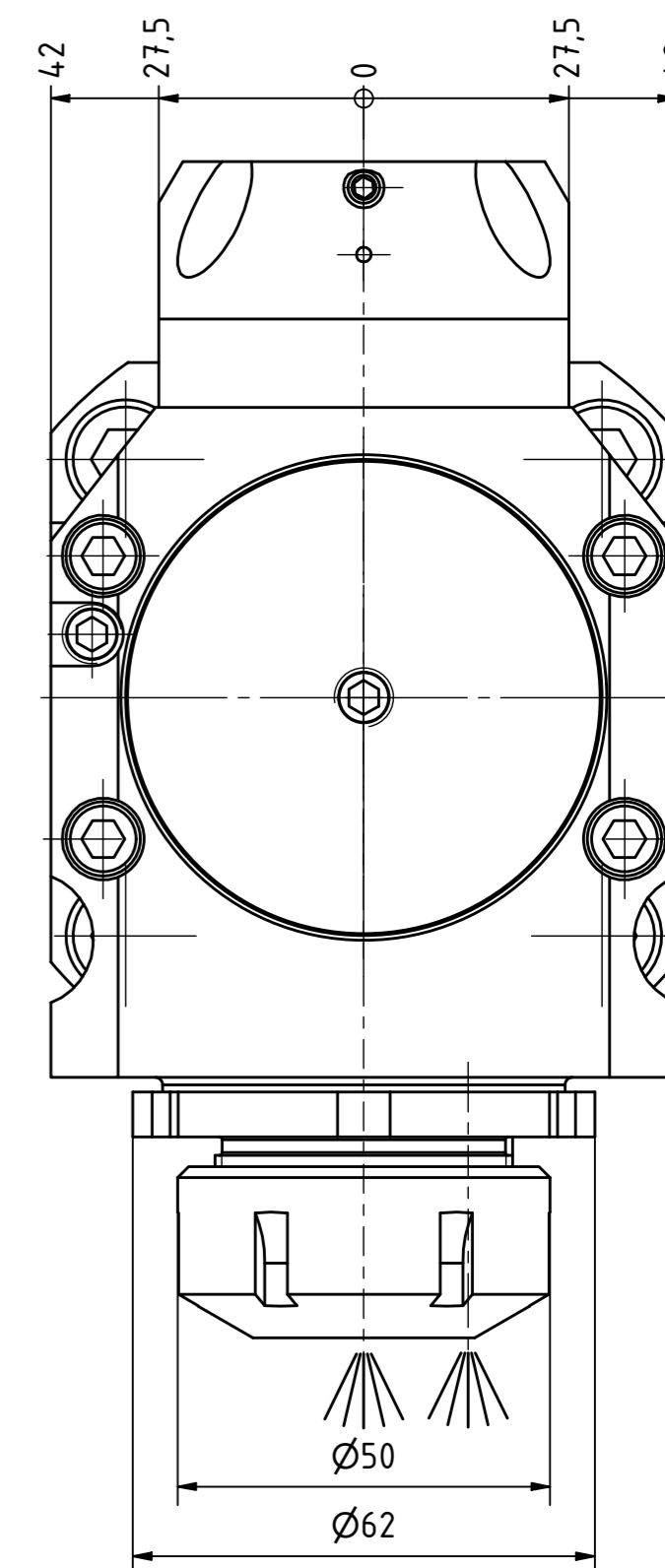
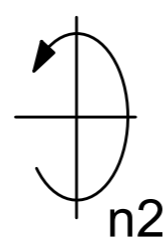
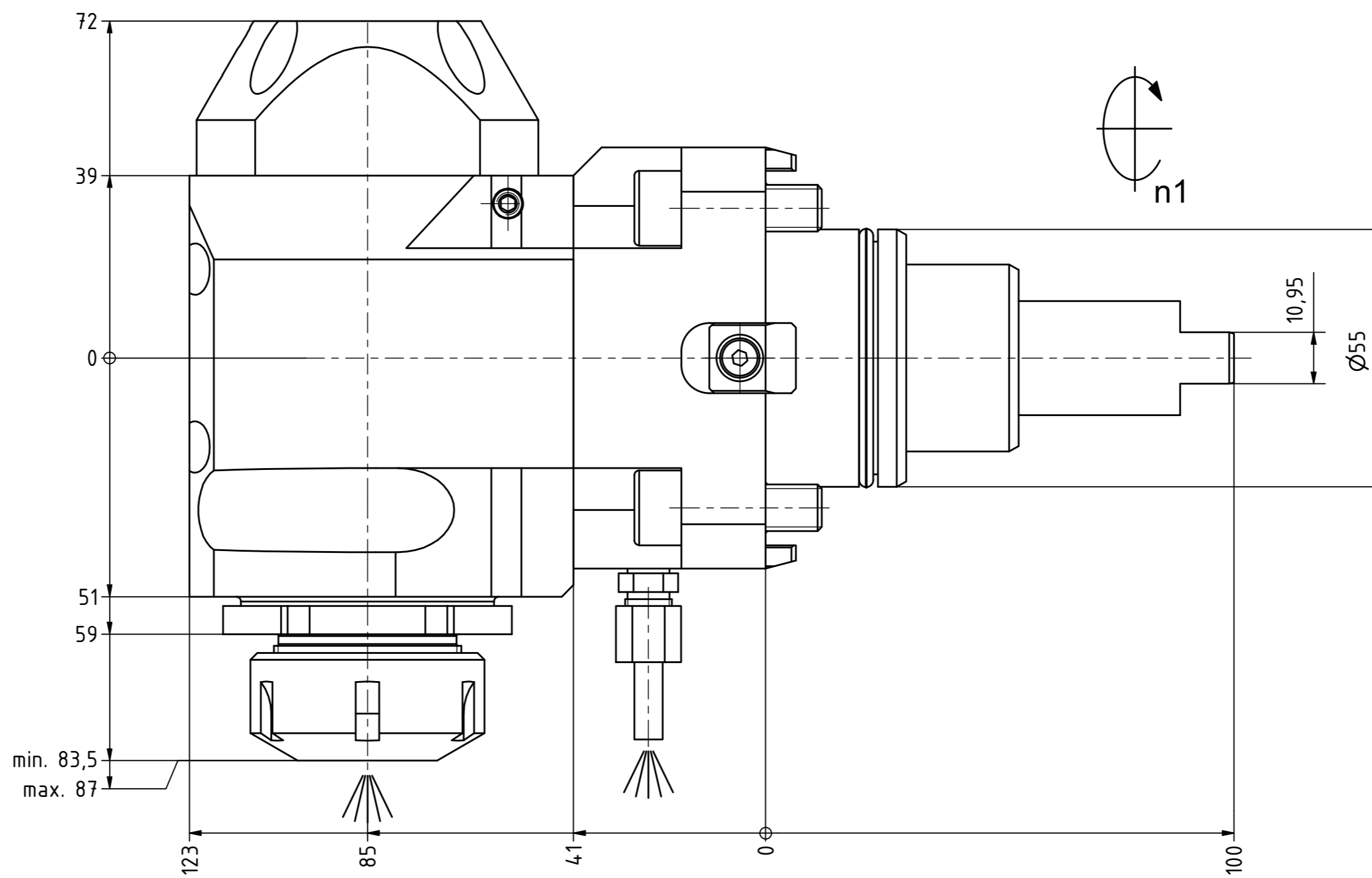

Hakenschlüssel
mit Nase
Hook wrench with
nose end
DIN1810 A 58x62



Spannzangenschlüssel
Clamping wrench
232

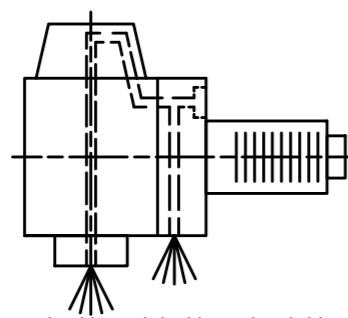

Innen- und Aussenkuehlung / Inside and outside coolant supply
Kein Trockenlauf / No dry run
Kuehlmittelfiltrierung-50µ / coolant filtration-50µ

Bemerkung - Note

Nicht ohne Kuehlmittel betreiben!
Not for use without coolant-fluid!

Technische Daten - technical data

Weight = 7.010 [kg]
Torque max. (M1/M2) = 50 / 25 [Nm]
Speed max. (n1/n2) = 6000 / 12000 [1/min]
Gear ratio (i)=n1:n2 = 1:2
Pressure (pmax) = 70 [bar]

Benennung - Title

Radial Bohr und Fräskopf
Radial drilling and milling head



Nr. - No.
60.5532VL4IK1

Technische Aenderungen vorbehalten!
Subject to technical modifications!
IDENT: DEWS242103

REV: -/C

MNR.
228387



Copyright EWS Tool Technologies
Weitergabe und Vervielfaeltigung dieser Unterlage,
Verwertung und Mitteilung ihres Inhalts nicht
gestattet, soweit nicht ausdrecklich zugestanden.
Zuwoerhandlungen verpflichten zu Schadenersatz.