

Gewindebohrungen für Winkelausrichtung.  
Thread holes for angle adjusting.

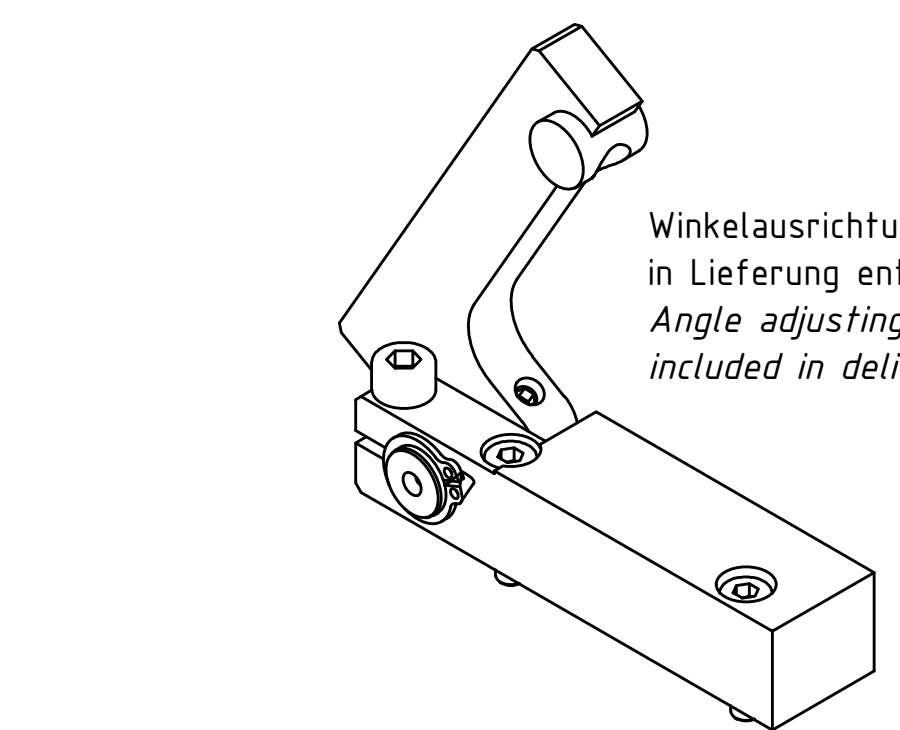
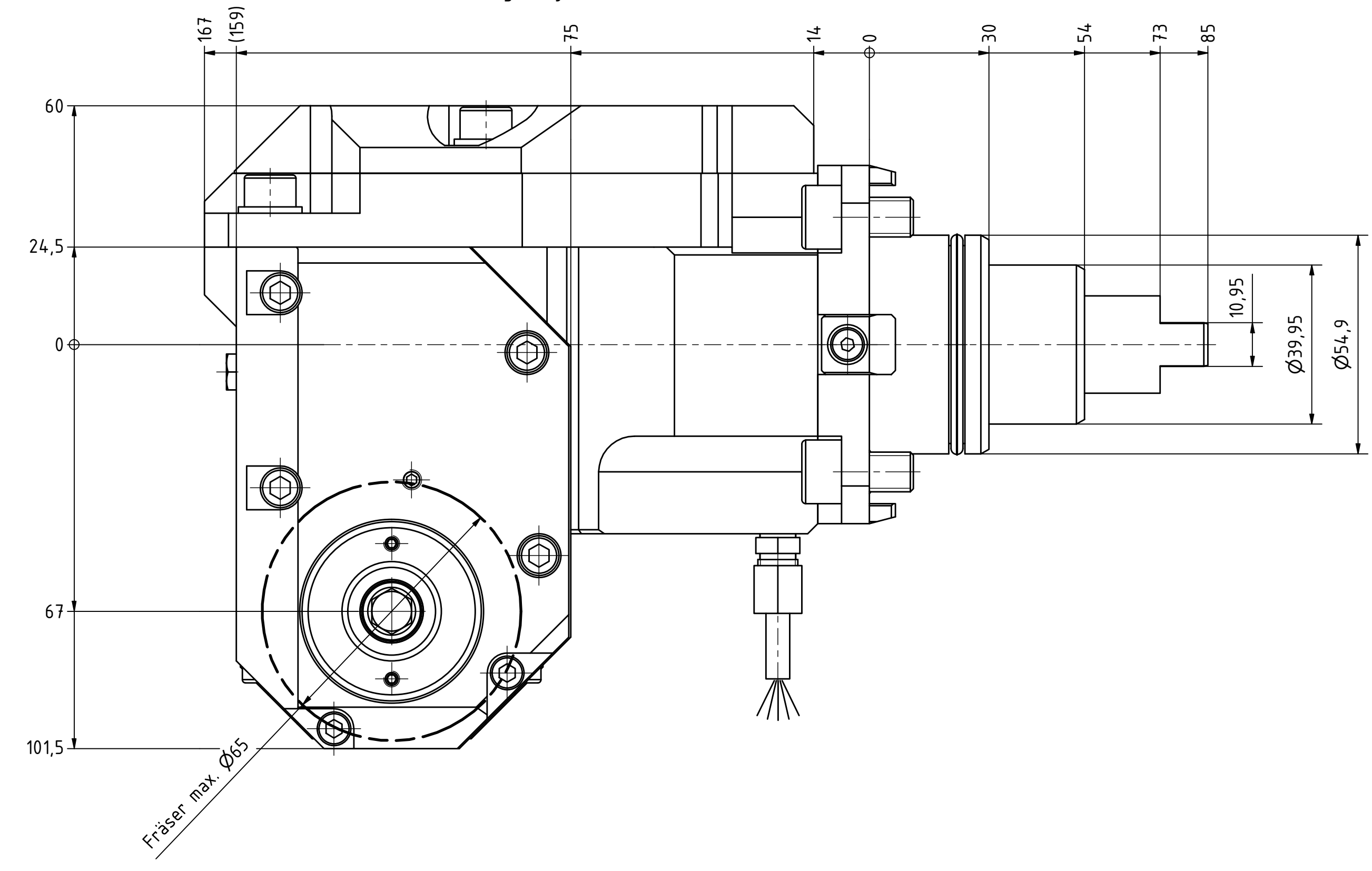
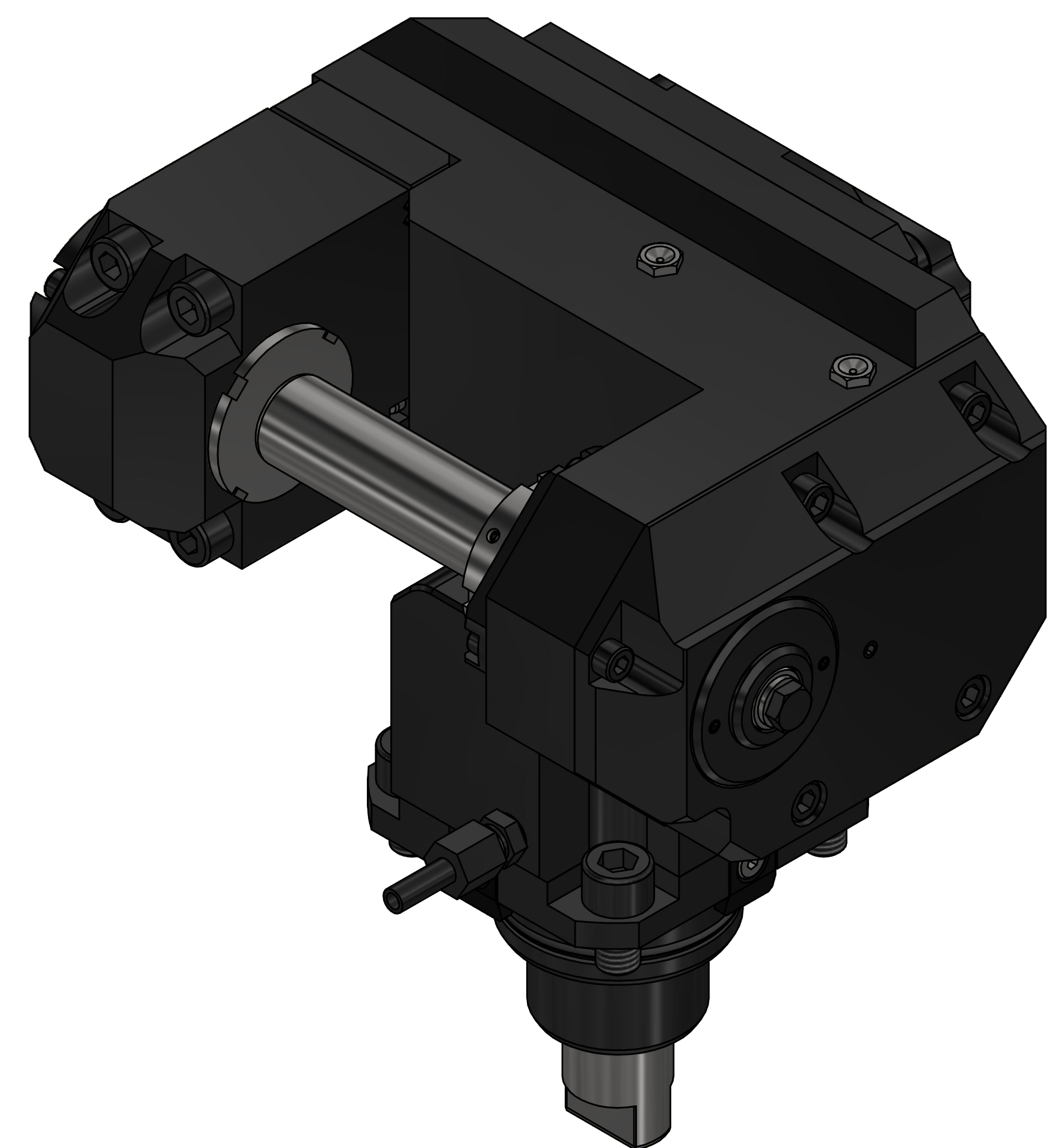
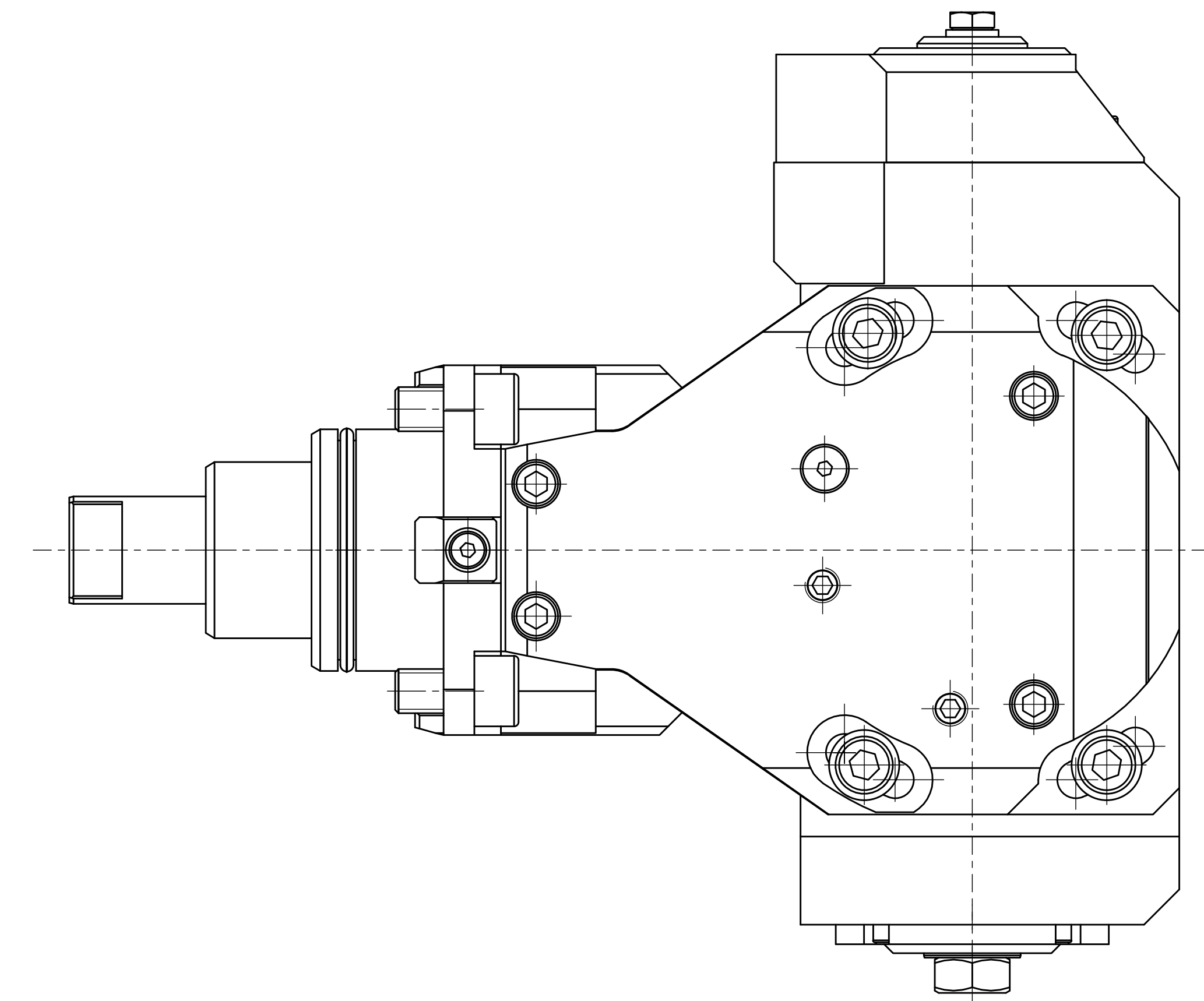
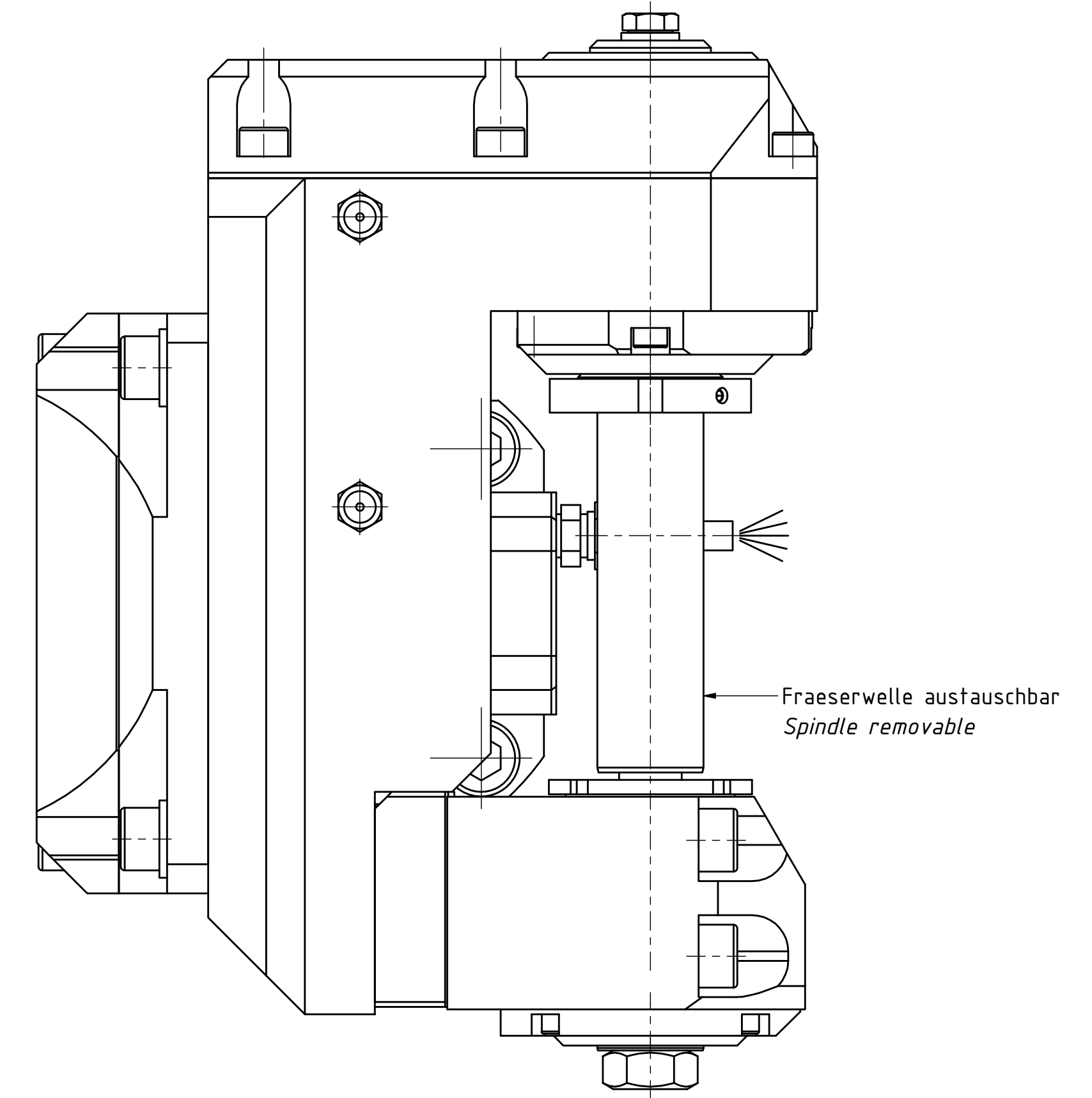
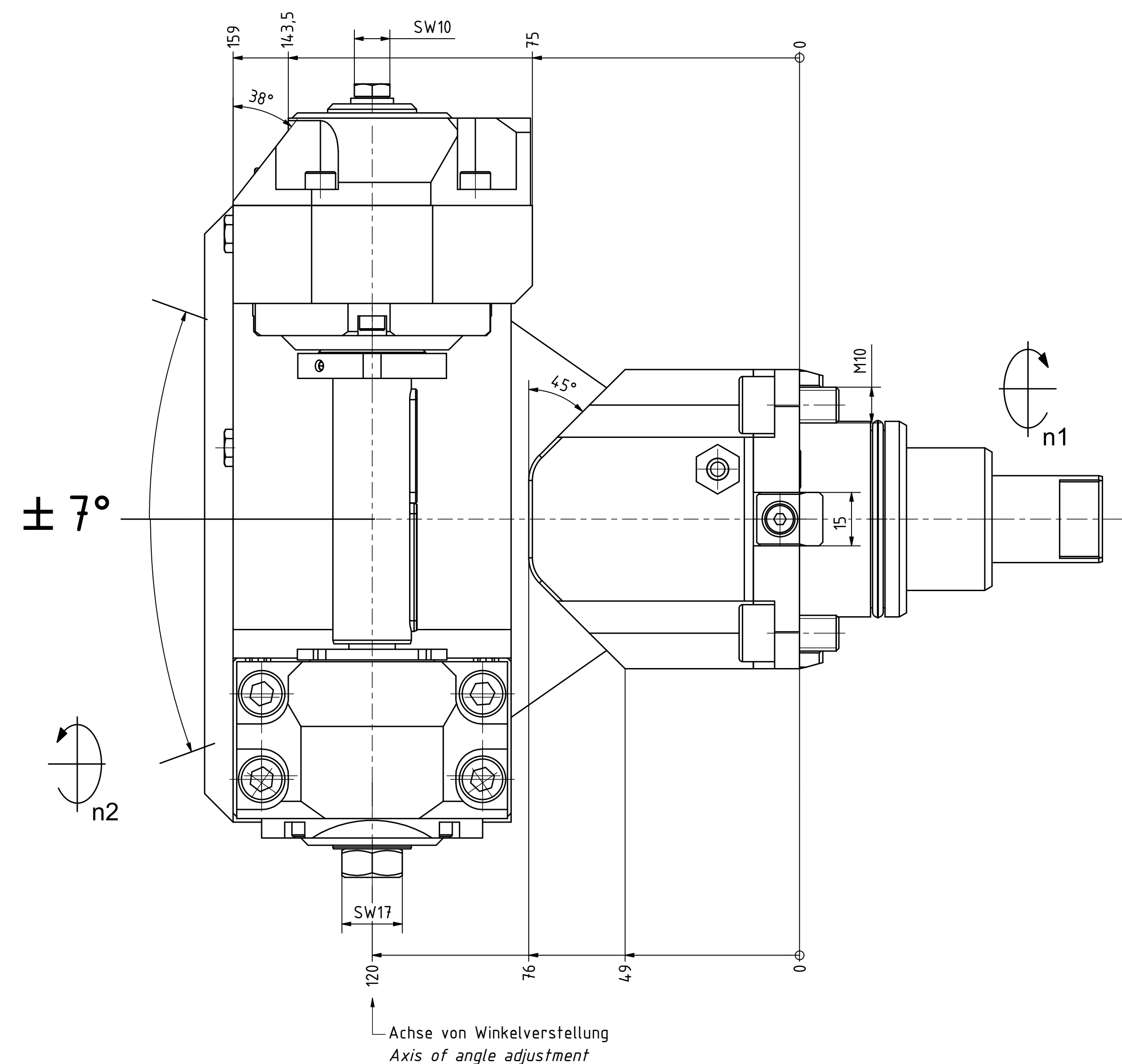
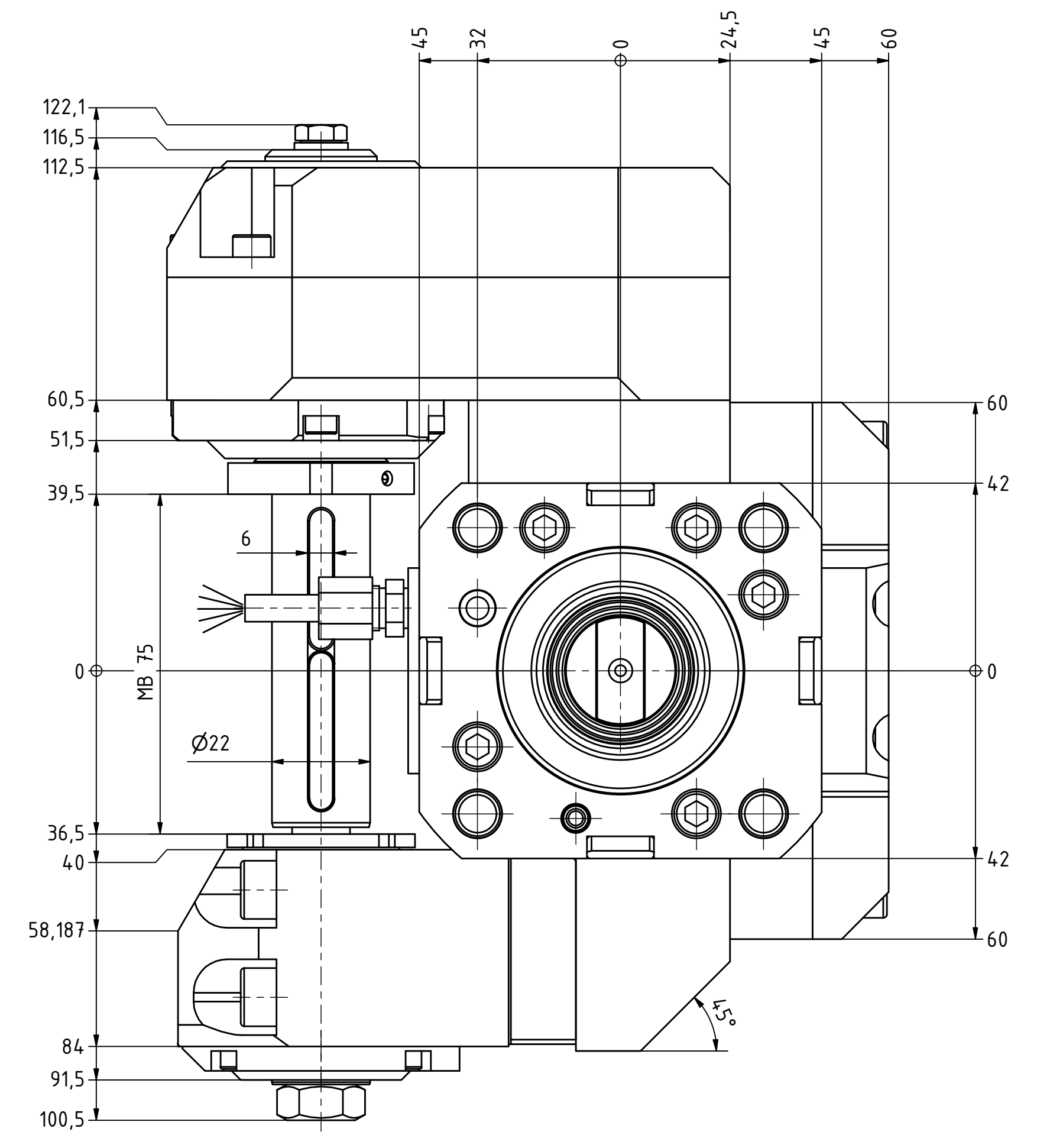
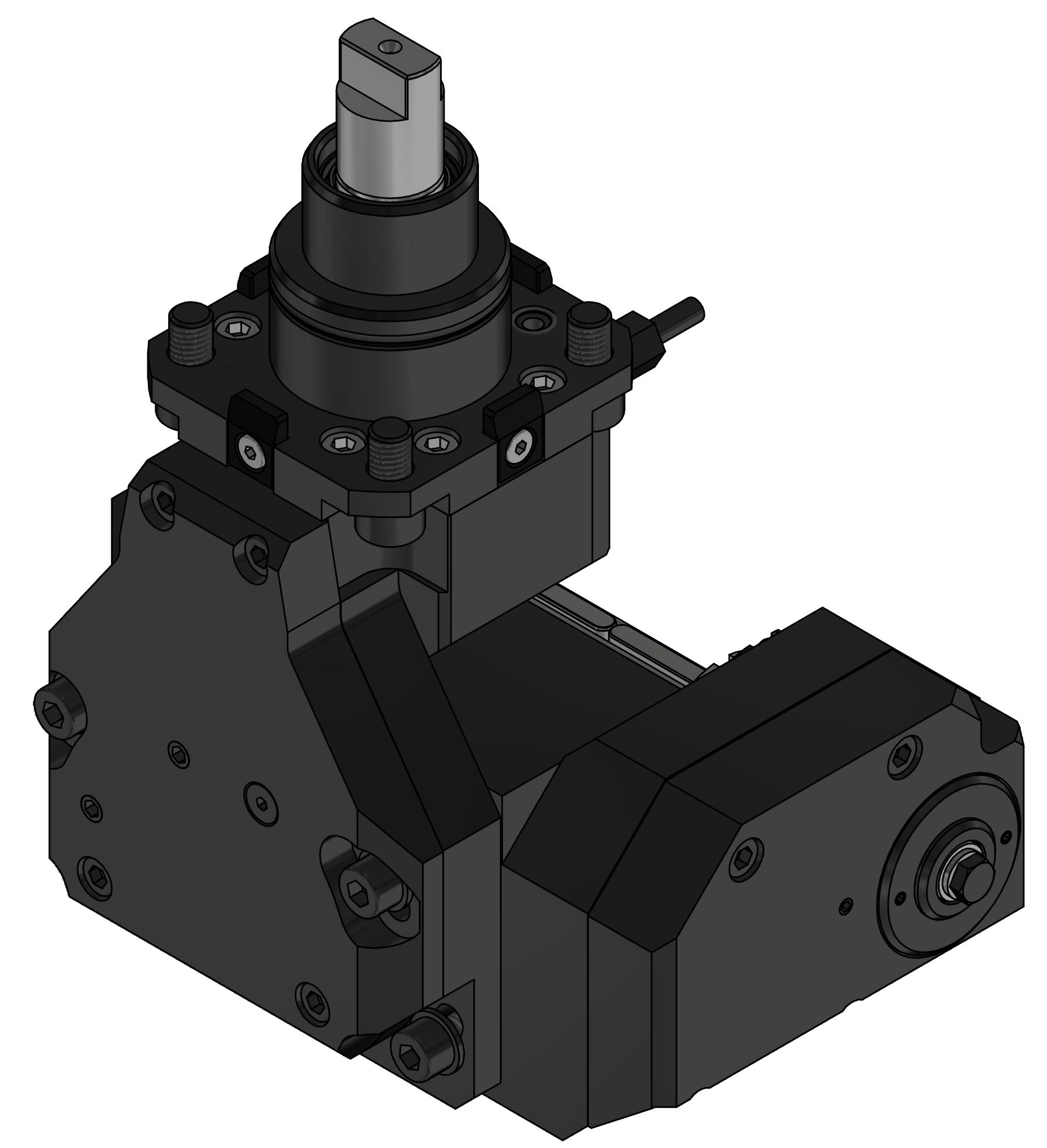
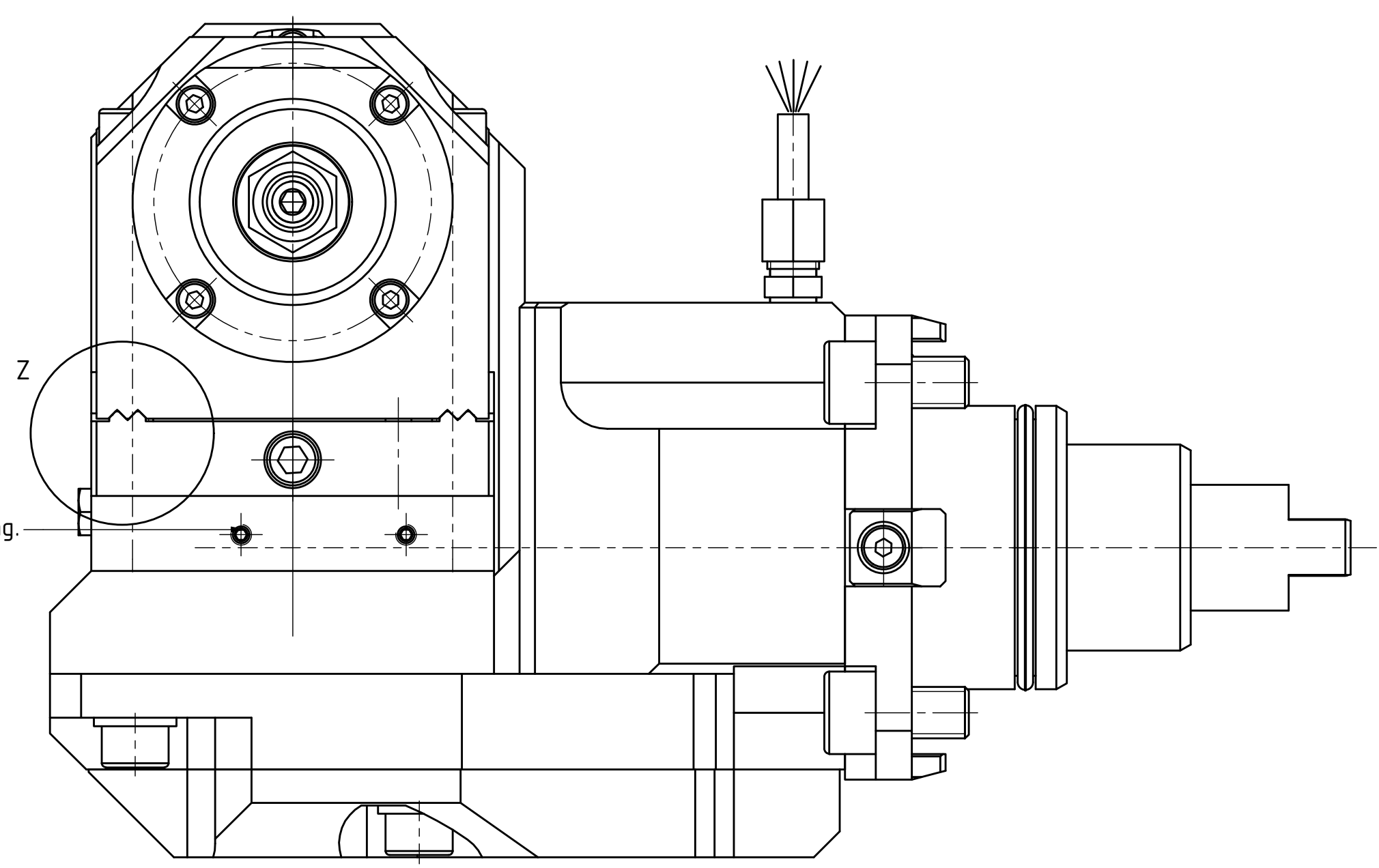

Winkelausrichtung & CD-ROM  
in Lieferung enthalten!  
Angle adjusting & CD-ROM  
included in delivery!

Beide Nachbarstationen nicht verwendbar!  
Both neighbour stations are not useable!

Bezeichnung - Name

Technische Daten - Technical data  
Weight = 16,728 [kg]  
Torque max. [N/m] = 43 / 80 [Nm]  
Speed max. [1/min] = 6000 / 3000 [1/min]  
Gear ratio [n1/n2] = 2:1

Bezeichnung - Name  
Radial Scheibenfräserkopf versetzt  
Saw milling spindle offset

Copyright EWS Tool Technologies  
Weitergabe und Vervielfältigung dieser Unterlage, Vervielfältigung und Mitteilung ohne schriftliche Genehmigung, soweit nicht ausdrücklich zugestanden. Zwischenhandlungen verpflichten zu Schadenersatz.  
EWS  
84.5522VLHP212TKWZ67MB75  
227864

