

Spannzange / collet ER25 DIN6499
Spannbereich / clamping range: 1,0 - 16,0

Gewindebohrzange / tapping collet
ET-1-25 M3-M12

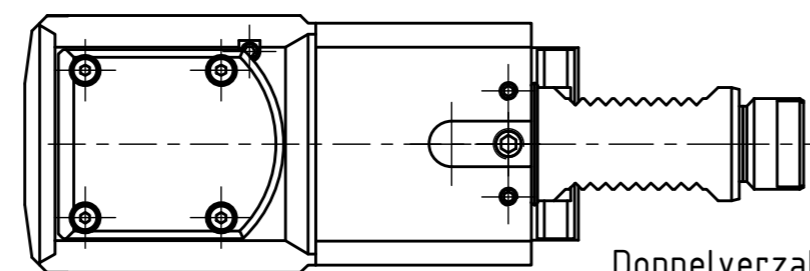

Doppelverzahnung Lizenz Traub
double tooth system licence Traub

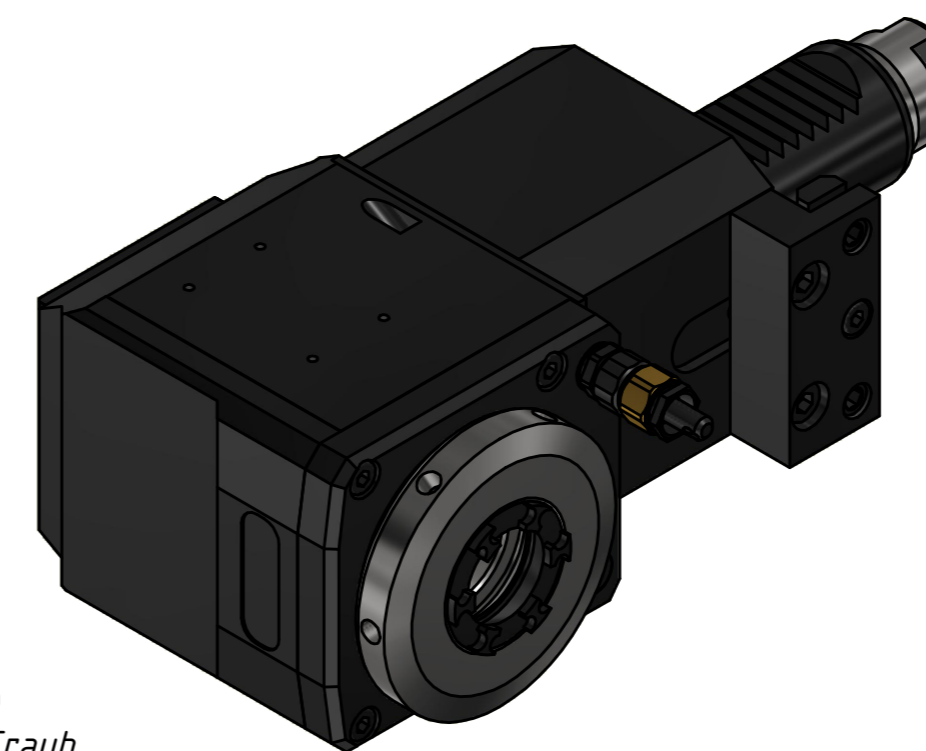

Hakenschlüssel mit Nase
Hook wrench with nose end
DIN1810 A 52x55

Spannzangenschlüssel für innenliegende Mutter
Clamping wrench for internal collet
225AX

Copyright EWS Tool Technologies
Weitergabe und Vervielfältigung dieser Unterlage, Verwertung und Mitteilung ihres Inhalts nicht gestattet, soweit nicht ausdrücklich zugestanden. Zuwiderhandlungen verpflichten zu Schadenersatz.

Bemerkung - Note	Technische Daten - technical data Weight = 4.621 [kg] Torque max. (M1/M2) = 25 / 25 [Nm] Speed max. (n1/n2) = 8000 / 8000 [1/min] Gear ratio (i)=n1:n2 = 1:1	Benennung - Title Radial Bohr und Fräskopf Radial drilling and milling head	<div style="display: flex; justify-content: space-between;"> <div data-bbox="2226 1915 2463 2043"> <small>EWS Weigle GmbH & Co. KG Maybachstr. 1 D-73066 Uhingen www.ews-tools.de</small> </div> <div data-bbox="2463 1915 2700 2043"> <small>Technische Änderungen vorbehalten! Subject to technical modifications!</small> IDENT: DEWS238992 MNR. </div> <div data-bbox="2700 1915 2929 2043"> REV: -/A 227861 </div> </div>
------------------	--	---	--