

Spannzange / collet ER25 DIN6499
Spannbereich / clamping range: 1,0 - 16,0

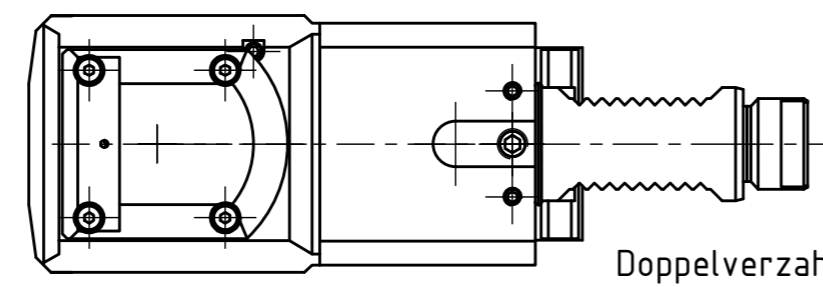

Doppelverzahnung Lizenz Traub
double tooth system licence Traub

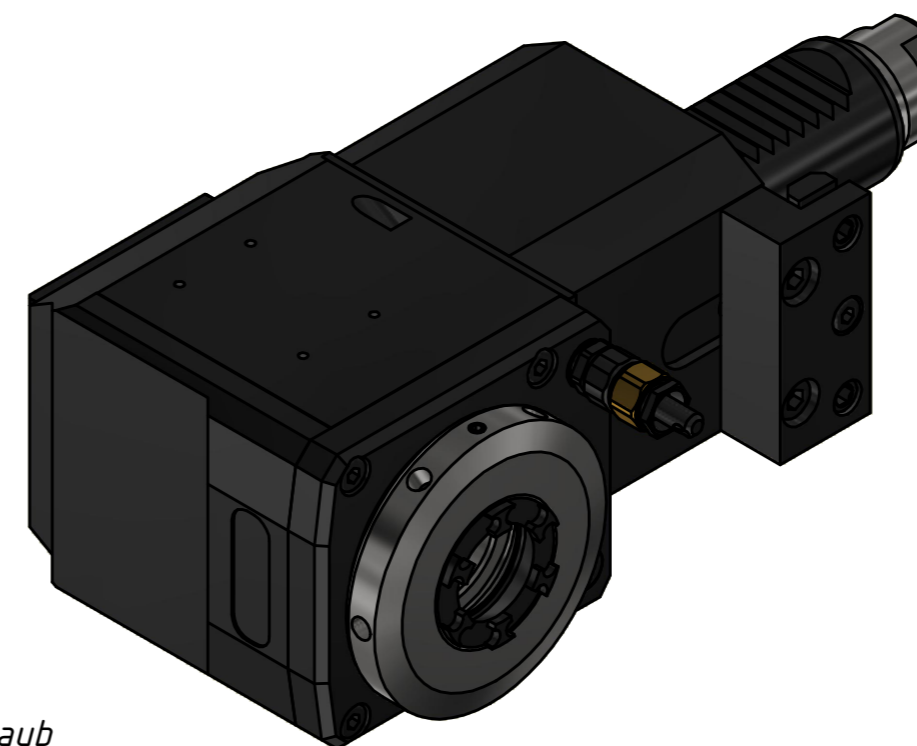

Hakenschlüssel mit Nase
Hook wrench with nose end
DIN1810 A 52x55

Spannzangenschlüssel für innenliegende Mutter
Clamping wrench for internal collet
225AX

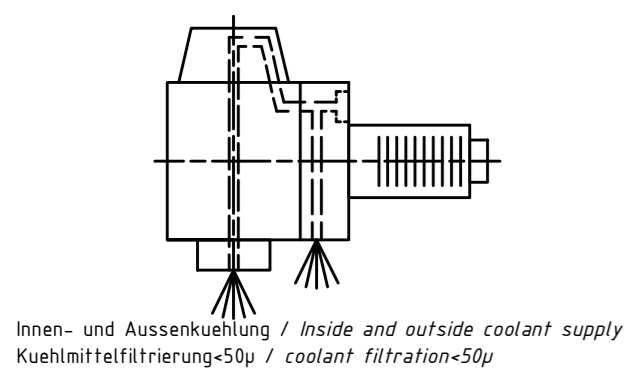

Bemerkung - Note Für Trockenlauf geeignet! Use without coolant fluid allowed!	Technische Daten - technical data Weight = 4,825 [kg]
	Torque max. (M1/M2) = 25 / 25 [Nm]
	Speed max. (n1/n2) = 8000 / 8000 [1/min]
	Gear ratio (i)=n1:n2 = 1:1
	Pressure (pmax) = 70 [bar]

Benennung - Title Radial Bohr und Fräskopf Radial drilling and milling head

EWS Tool Technologies <small>EWS Weigle GmbH & Co. KG Maybachstr. 1 D-73066 Uhlingen www.ews-tools.de</small>	Technische Aenderungen vorbehalten! Subject to technical modifications! IDENT: DEWS238373	MNR. REV: -/A 227813
Nr. - No. 60.3025TC600RLIKDIMX100A35		

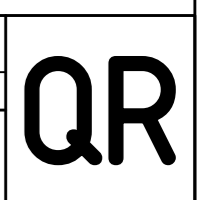

Copyright EWS Tool Technologies
Weitergabe und Vervielfaeltigung dieser Unterlage,
Verwertung und Mitteilung ihres Inhalts nicht
gestattet, soweit nicht ausdrecklich zugestanden.
Zuwiderhandlungen verpflichten zu Schadenersatz.