

Fraeserwelle austauschbar  
Spindle removable

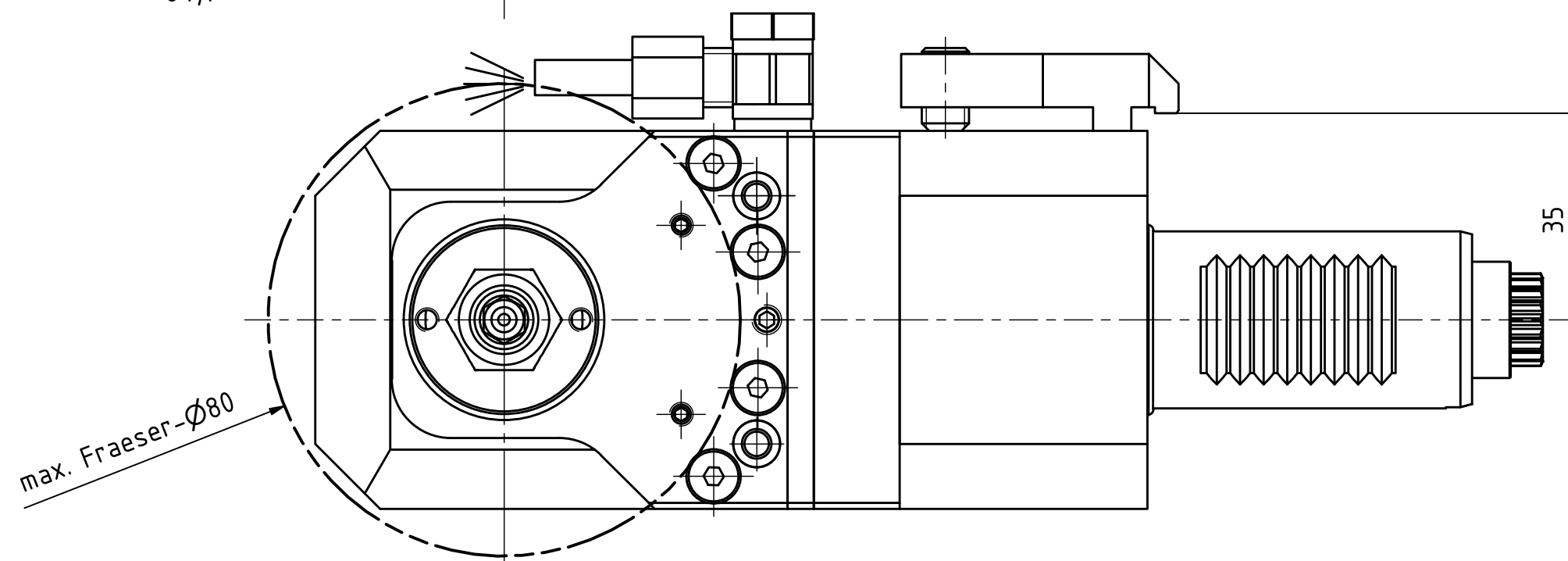

Copyright **EWS Tool Technologies**  
Weitergabe und Vervielfältigung dieser Unterlage,  
Verwertung und Mitteilung ihres Inhalts nicht  
gestattet, soweit nicht ausdrücklich zugestanden.  
Zuwendungen verpflichten zu Schadenersatz.

Bemerkung - Note 	Technische Daten - technical data Weight = 4,649 [kg] Torque max. (M1/M2) = 20 / 60 [Nm] Speed max. (n1/n2) = 6000 / 2000 [1/min] Gear ratio (i)=n1:n2 = 3:1	Benennung - Title <b>Scheibenfräserkopf</b> <b>Radial saw milling head</b>	 EWS Weigle GmbH & Co. KG Maybachstr. 1 D-73066 Ulm/ingen www.ews-tools.de Nr. - No. <b>64.3010LE365I3EL</b>	Technische Änderungen vorbehalten! Subject to technical modifications! IDENT: DEWS237344 MNR. REV: -/B <b>227811</b>
----------------------	--	--	---	---

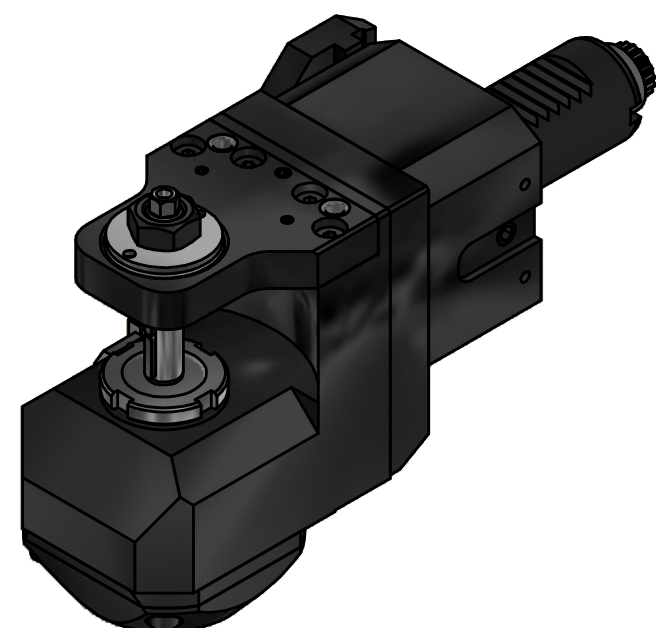
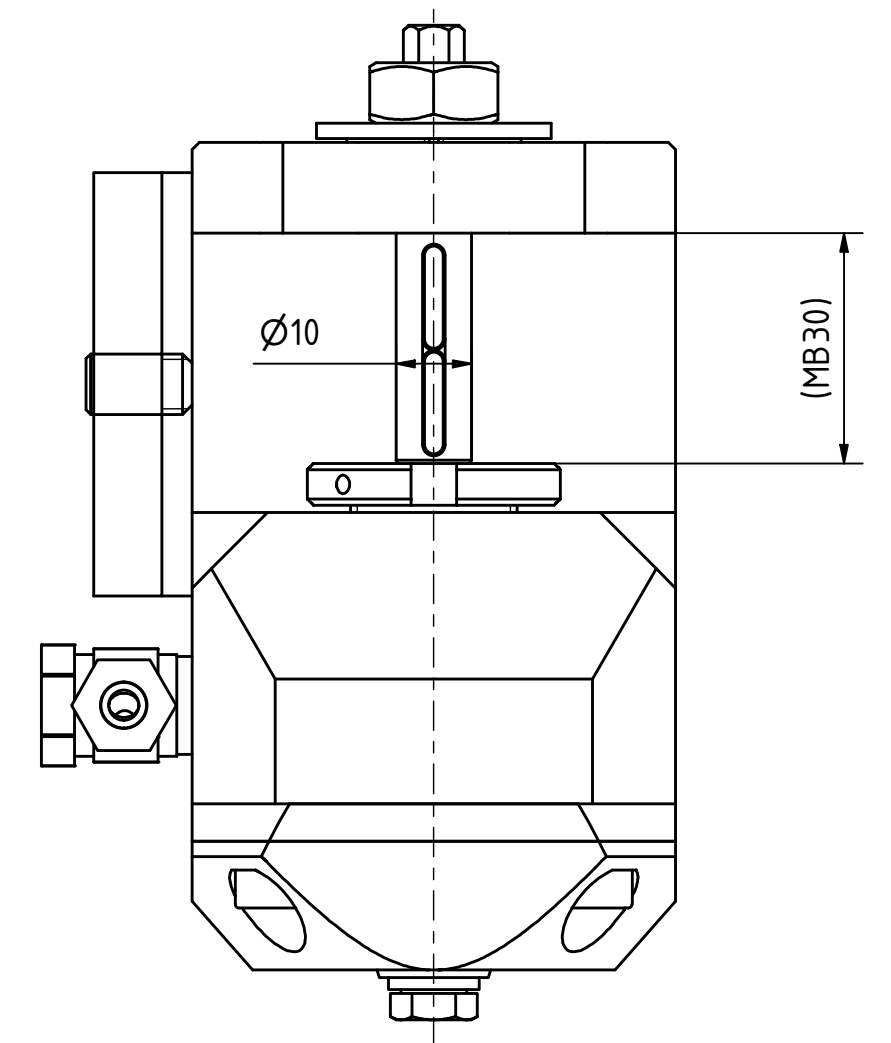
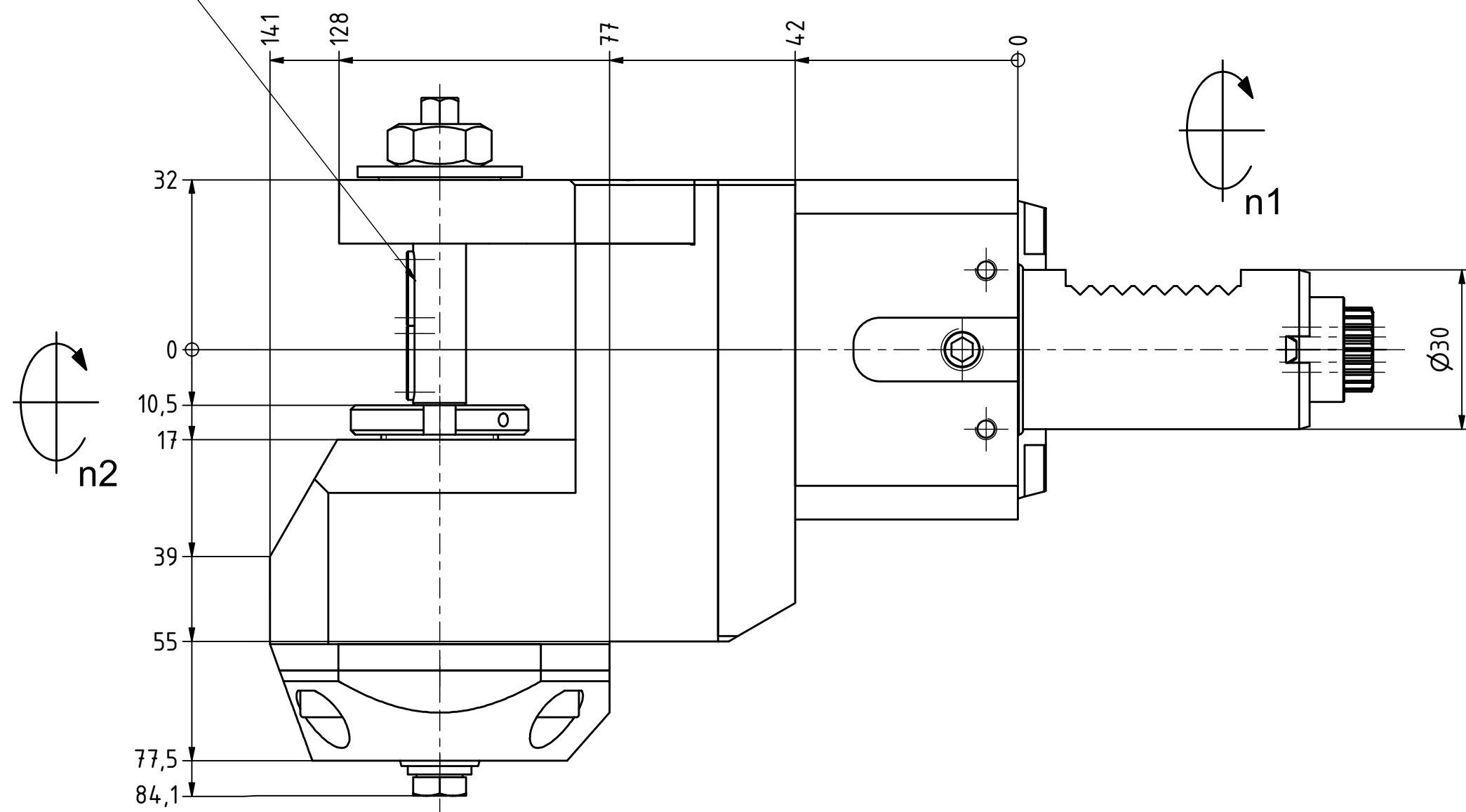
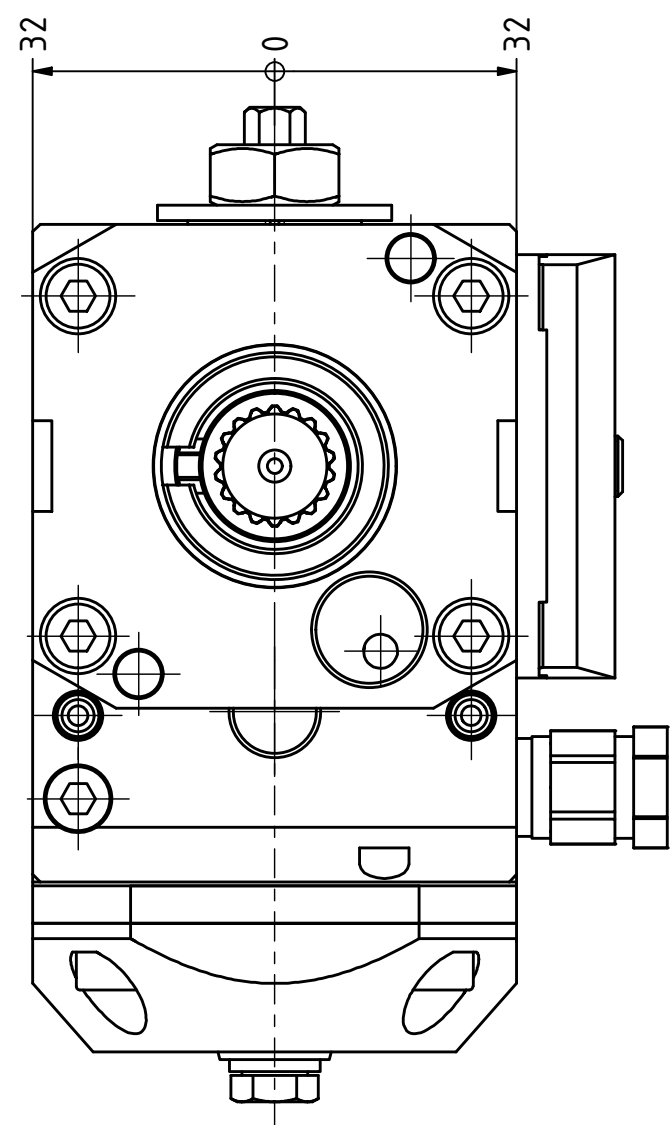