

Fraeserwelle austauschbar
Spindle removable

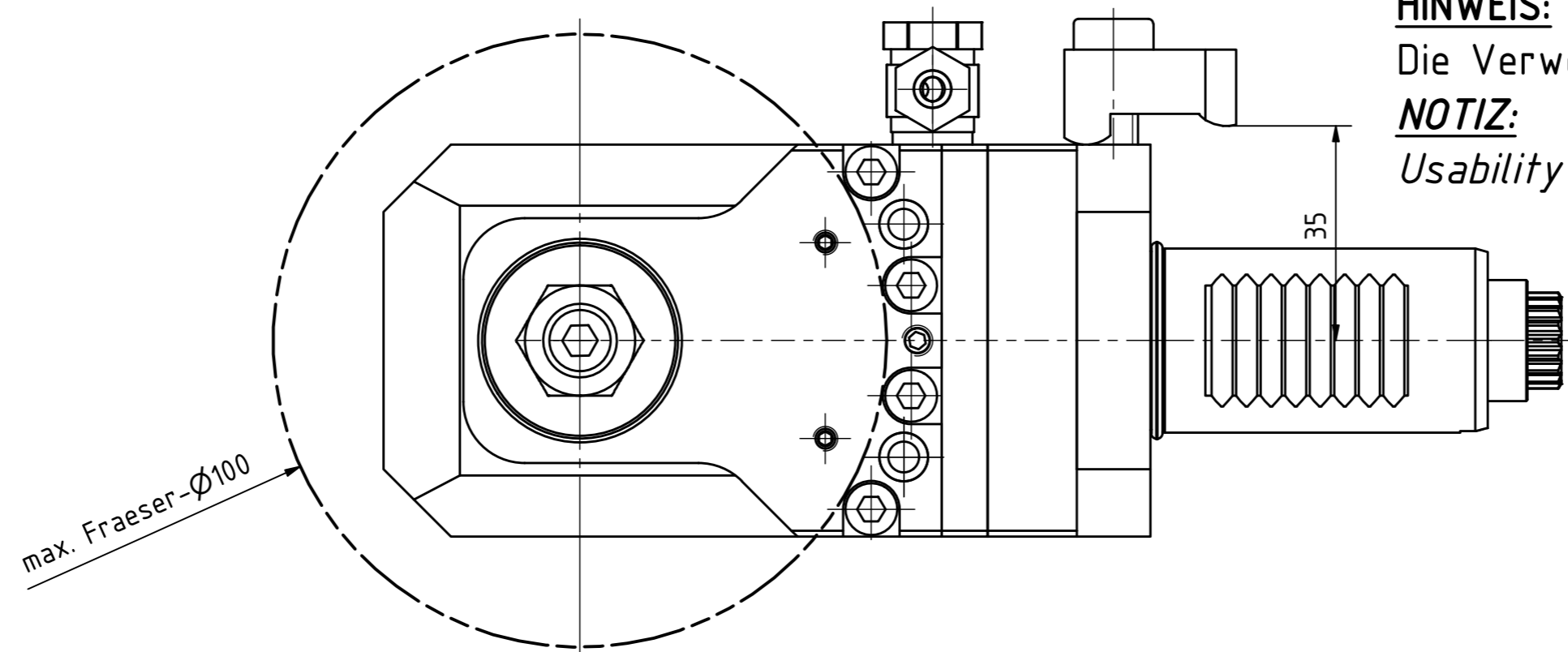
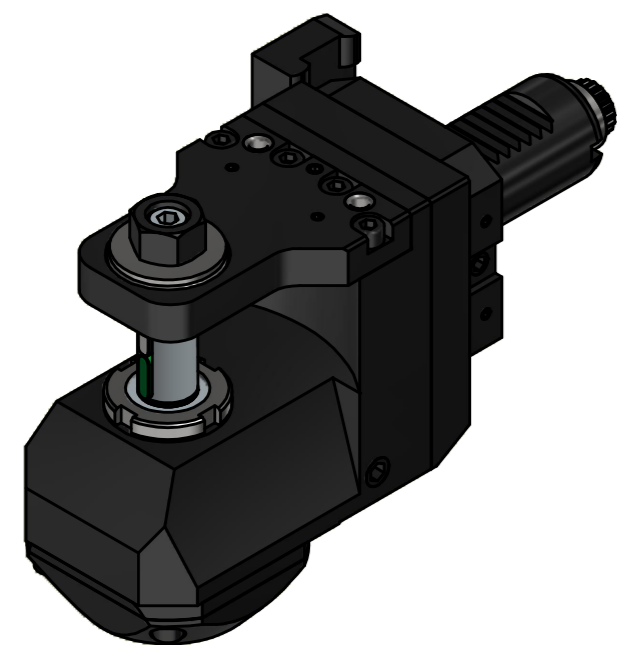
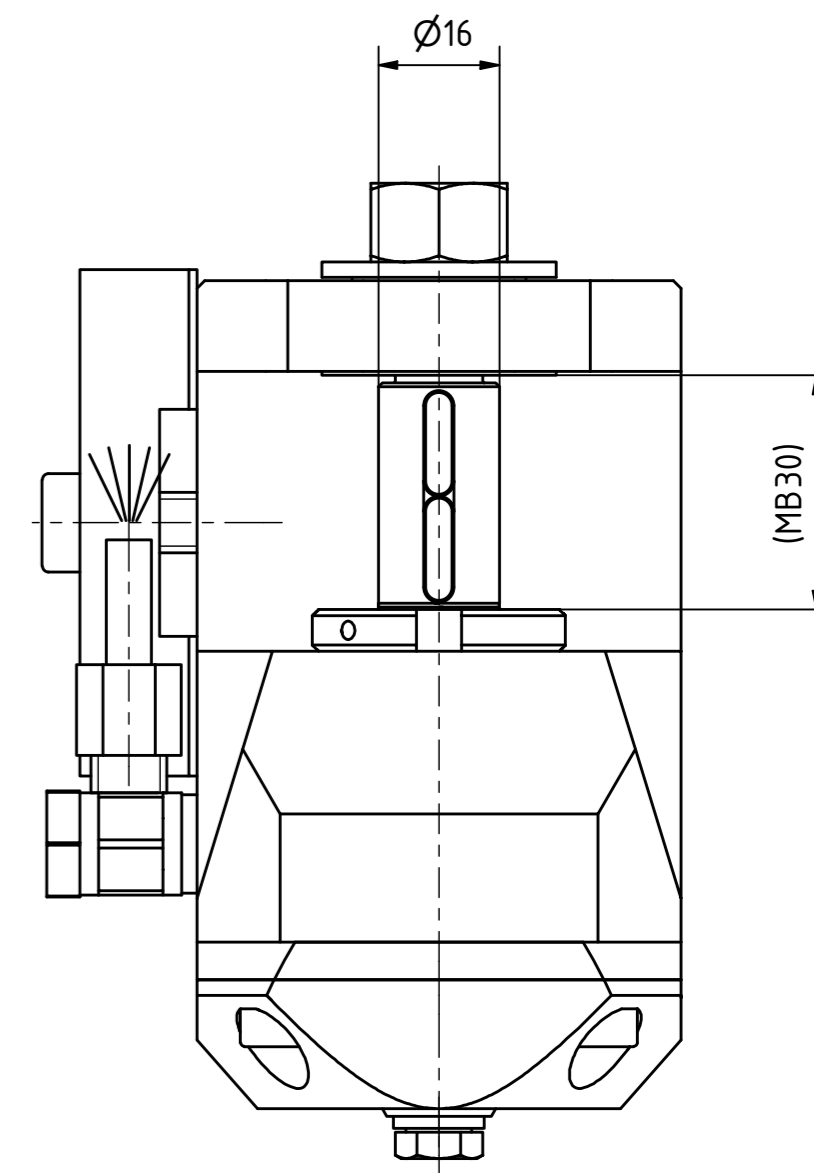
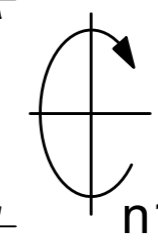
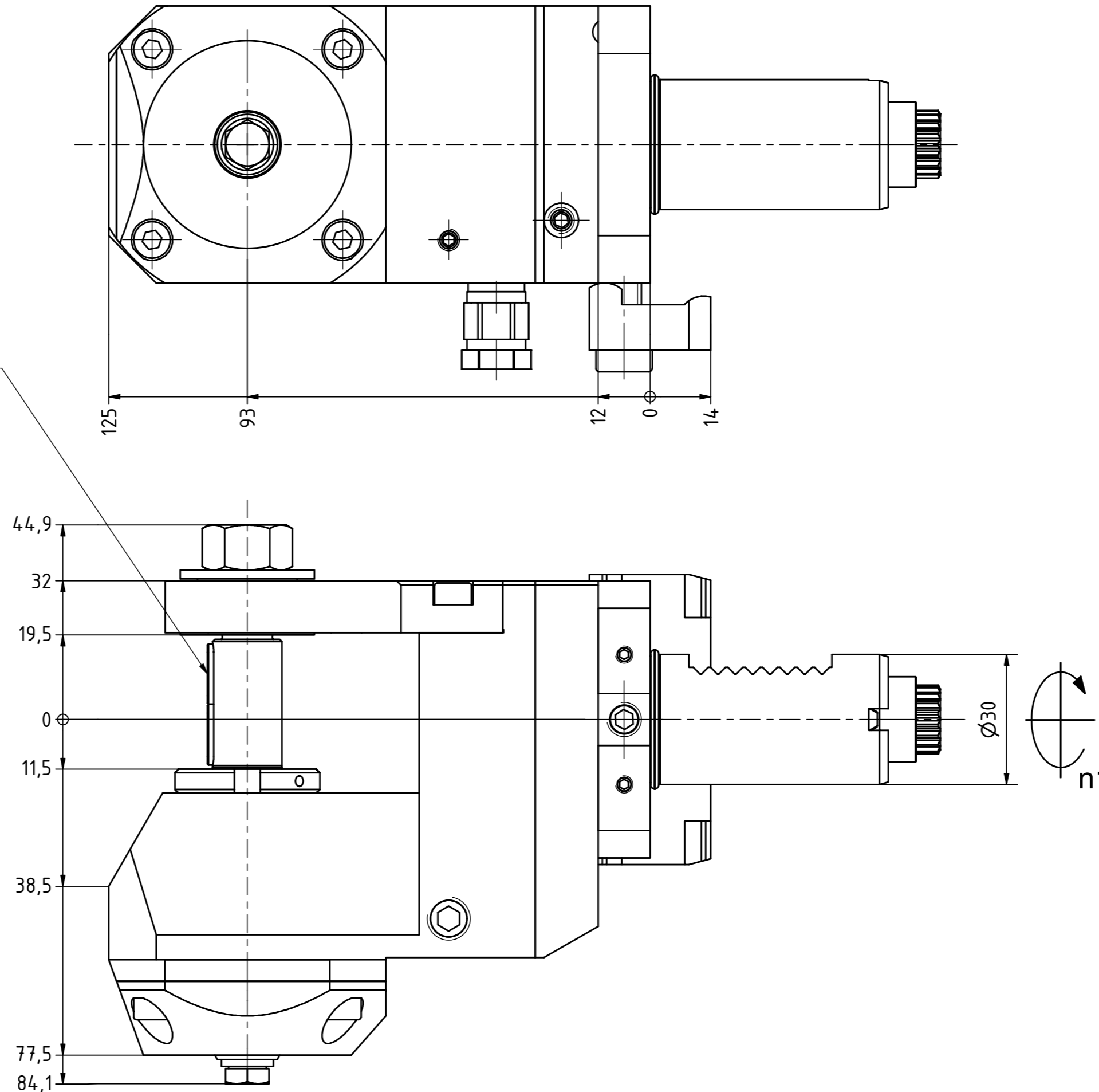
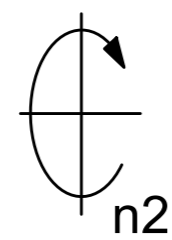

max. Fraeser-Ø100

HINWEIS:

Die Verwendbarkeit der Ausrichtungsplatte muss bestätigt werden.

NOTIZ:

Usability of the alignment plate need to be confirmed

Copyright **EWS Tool Technologies**
Weitergabe und Vervielfältigung dieser Unterlage,
Verwertung und Mitteilung ihres Inhalts nicht
gestattet, soweit nicht ausdrücklich zugestanden.
Zuwendungen verpflichten zu Schadenersatz.

Bemerkung - Note	Technische Daten - technical data Weight = 4,059 [kg] Torque max. (M1/M2) = 20 / 20 [Nm] Speed max. (n1/n2) = 6000 / 6000 [1/min] Gear ratio (i)=n1:n2 = 1:1	Benennung - Title Scheibenfräserkopf Radial saw milling head	<table border="1"> <tr> <td data-bbox="2226 1915 2463 1984"> EWS <small>EWS Weigle GmbH & Co. KG Maybachstr. 1 D-73066 Ulm/Ingen www.ews-tools.de</small> </td> <td data-bbox="2463 1915 2686 1984"> Technische Änderungen vorbehalten! Subject to technical modifications! IDENT: DEWS236663 </td> <td data-bbox="2686 1915 2789 1984"> REV: -/A MNR. </td> </tr> <tr> <td data-bbox="2226 1984 2463 2047"> Nr. - No. 64.3016E365GLOT13Ø100 </td> <td data-bbox="2463 1984 2686 2047"> 227785 </td> <td data-bbox="2789 1915 2908 2047"> QR </td> </tr> </table>	EWS <small>EWS Weigle GmbH & Co. KG Maybachstr. 1 D-73066 Ulm/Ingen www.ews-tools.de</small>	Technische Änderungen vorbehalten! Subject to technical modifications! IDENT: DEWS236663	 REV: -/A MNR.	Nr. - No. 64.3016E365GLOT13Ø100	227785	QR
EWS <small>EWS Weigle GmbH & Co. KG Maybachstr. 1 D-73066 Ulm/Ingen www.ews-tools.de</small>	Technische Änderungen vorbehalten! Subject to technical modifications! IDENT: DEWS236663	 REV: -/A MNR.							
Nr. - No. 64.3016E365GLOT13Ø100	227785	QR							