

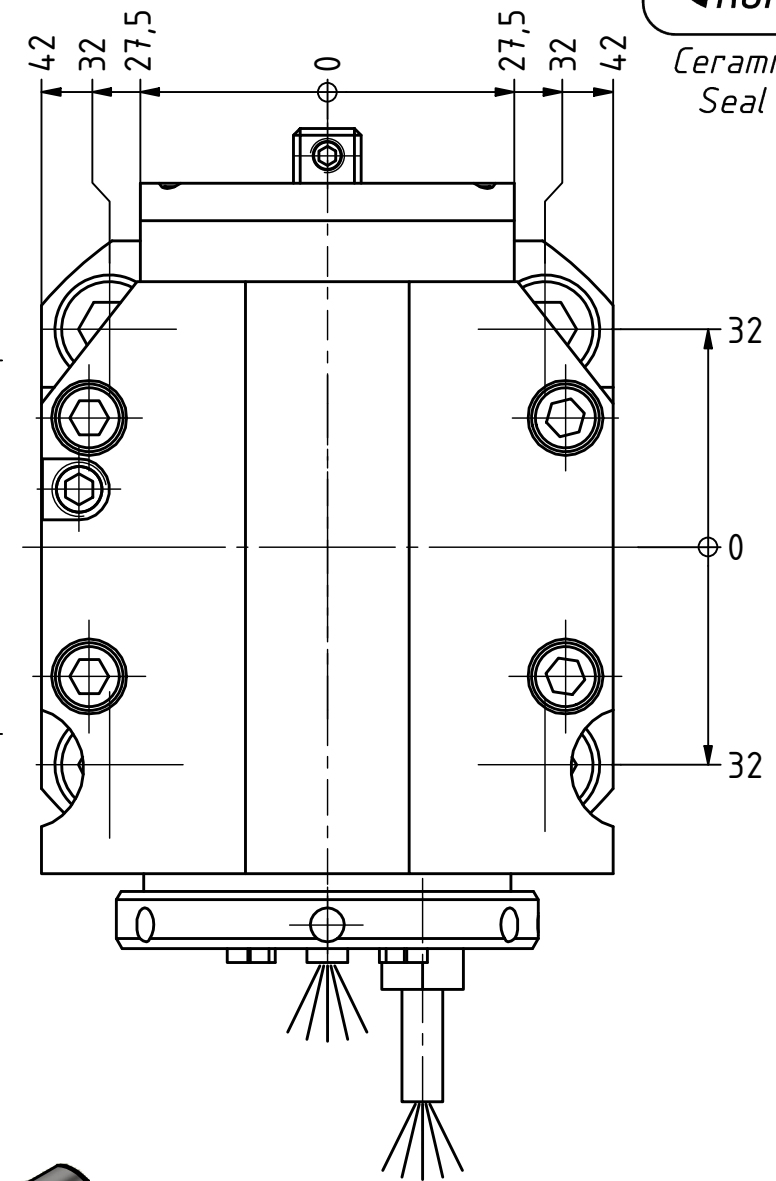

Ceramic Seal

Tech Details

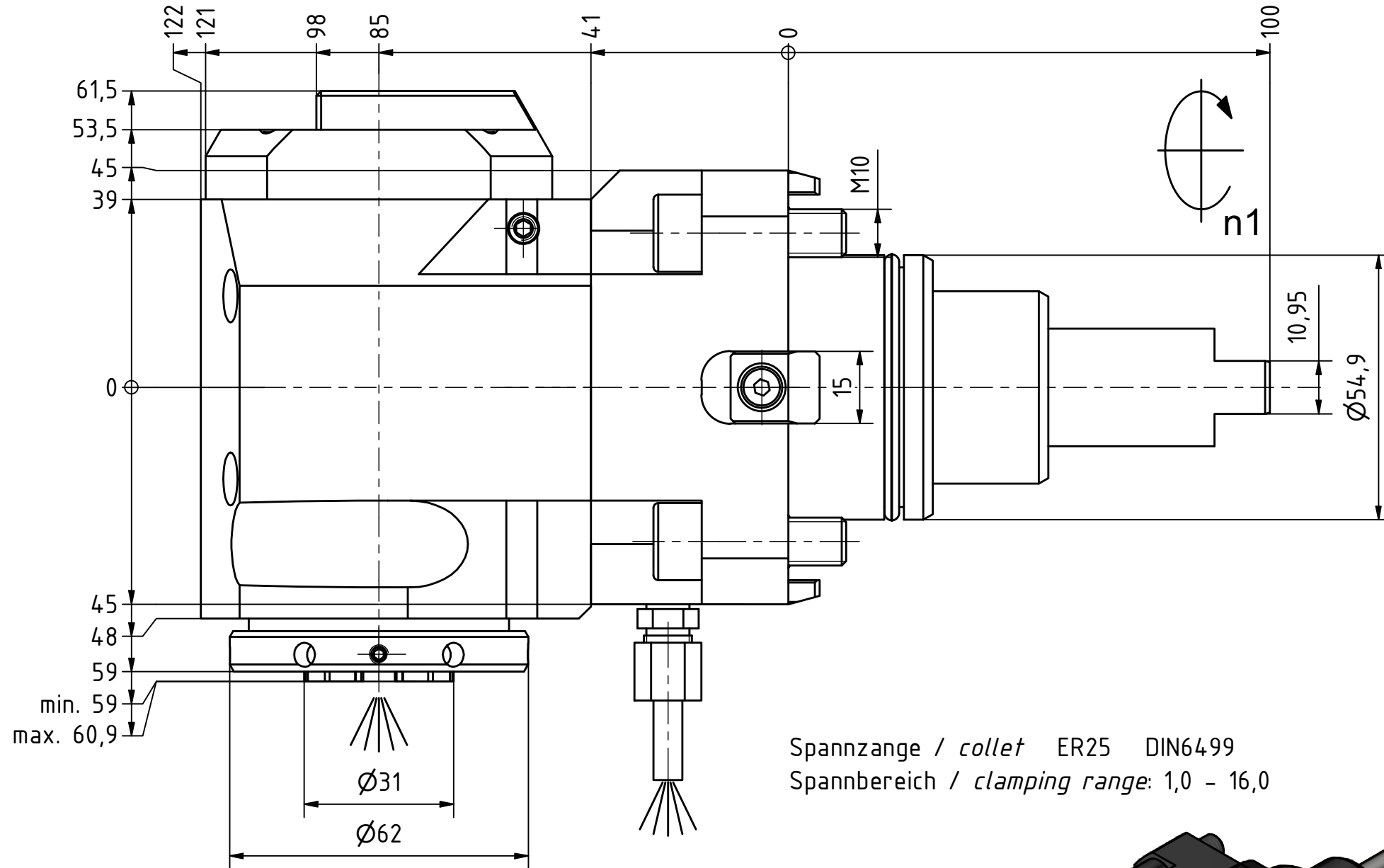

Spannzange / collet ER25 DIN6499  
 Spannbereich / clamping range: 1,0 - 16,0

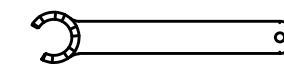
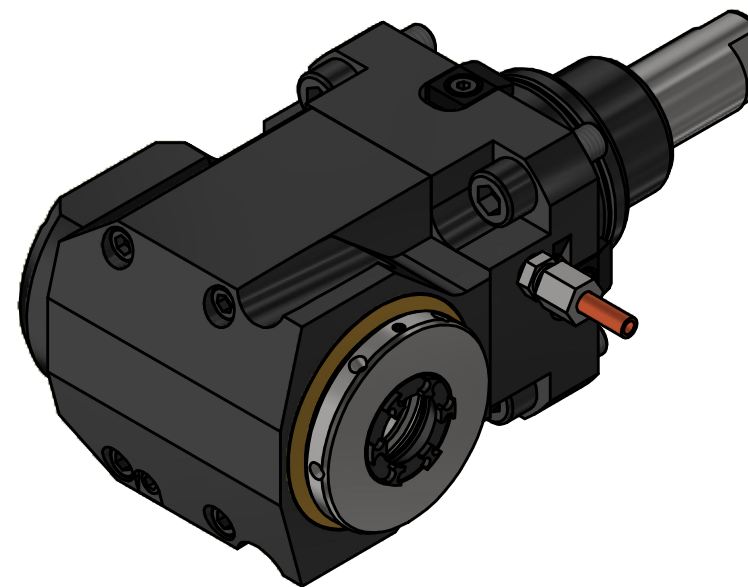

Spannzangenschlüssel für innenliegende Mutter  
 Clamping wrench for internal collet  
 225AX

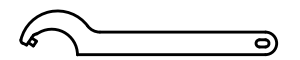

Hakenschlüssel mit Zapfen  
 Hook wrench with fixed pin  
 DIN1810 B 58x62

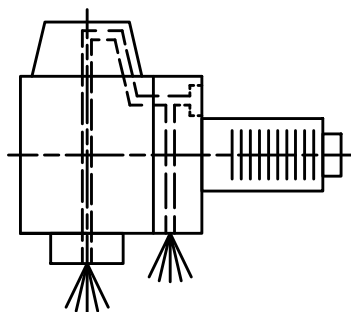

Innen- und Aussenkühlung / Inside and outside coolant supply  
 Kühlmittelfiltrierung <math>50\mu</math> / coolant filtration <math>50\mu</math>

Copyright **EWS Tool Technologies**  
 Weitergabe und Vervielfältigung dieser Unterlage, Verwertung und Mitteilung ihres Inhalts nicht gestattet, soweit nicht ausdrücklich zugestanden. Zuwiderhandlungen verpflichten zu Schadenersatz.

Bemerkung - Note  
 Für Trockenlauf geeignet!  
 Use without coolant fluid allowed!

Technische Daten - technical data	
Weight	= 6.503 [kg]
Torque max. (M1/M2)	= 50 / 50 [Nm]
Speed max. (n1/n2)	= 6000 / 6000 [1/min]
Gear ratio (i)=n1:n2	= 1:1
Pressure (pmax)	= 70 [bar]

Benennung - Title  
**Radial Bohr und Fräskopf**  
**Radial drilling and milling head**



Nr. - No.  
**60.5525VL4IKDIMZ59**

Technische Änderungen vorbehalten!  
 Subject to technical modifications!  
 IDENT: DEWS242507

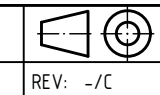

REV: -/C  
 MNR.  
**227768**

