

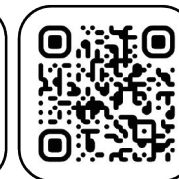

EWS.Varia



Ceramic Seal



Tech Details

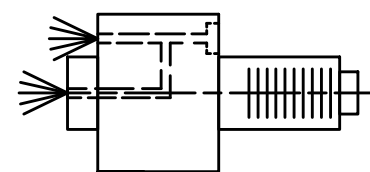
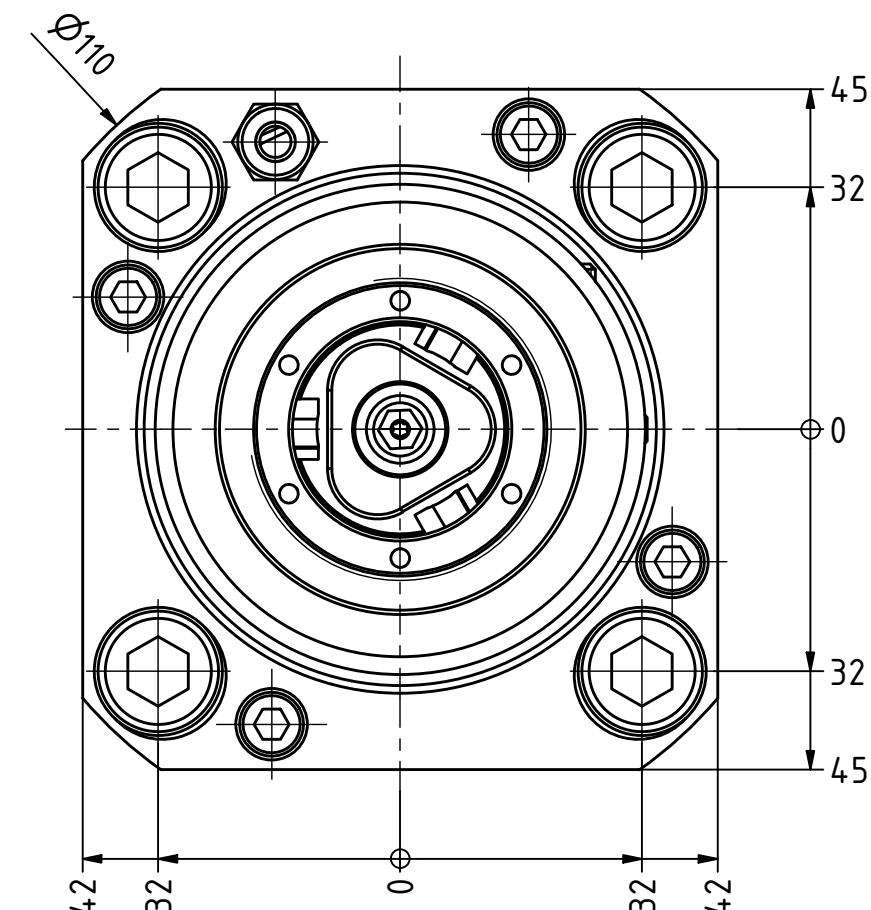
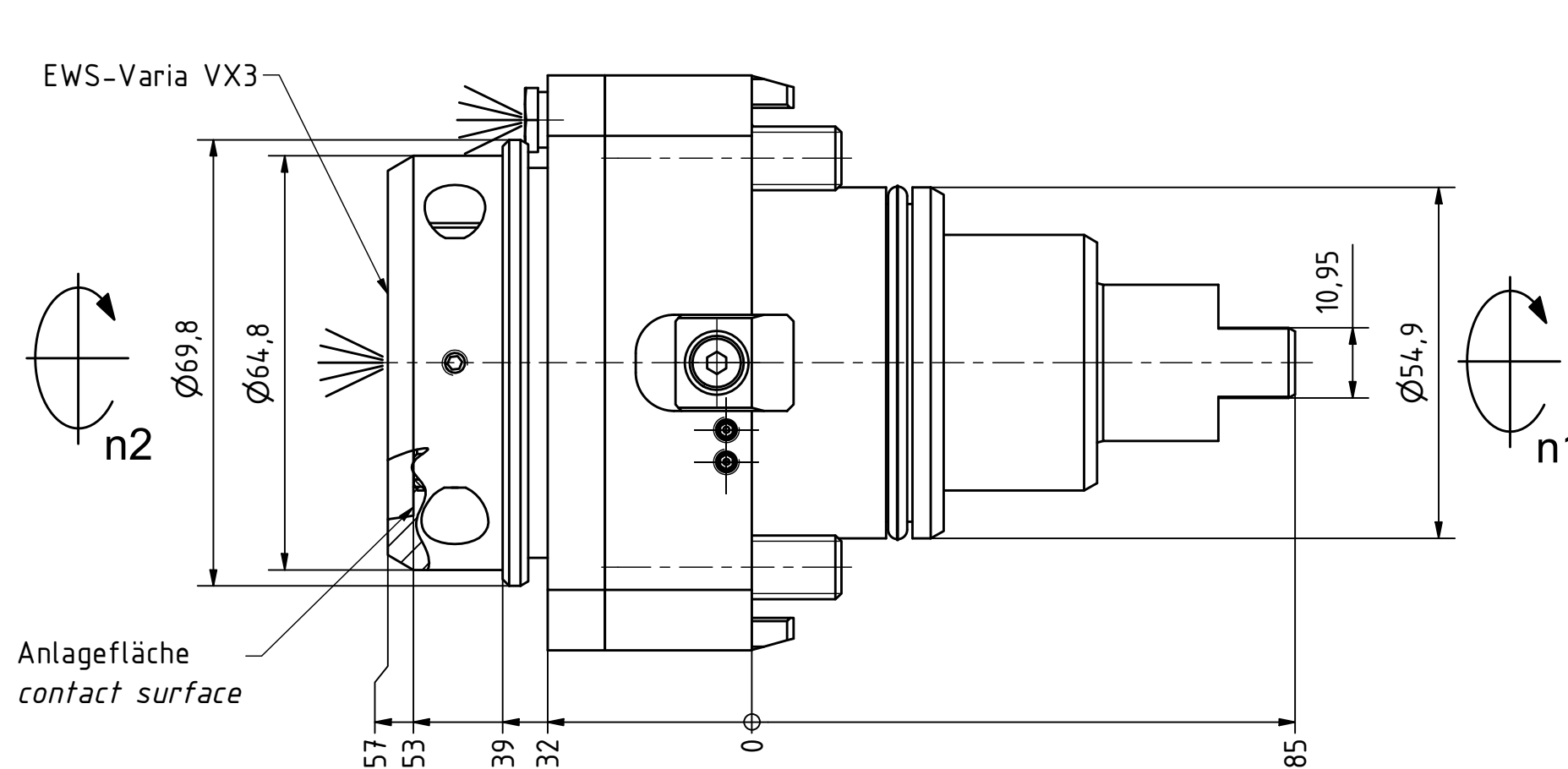

Innen- und Aussenkuehlung / Inside and outside coolant supply
Kuehlmittelfiltrierung 50μ / coolant filtration 50μ

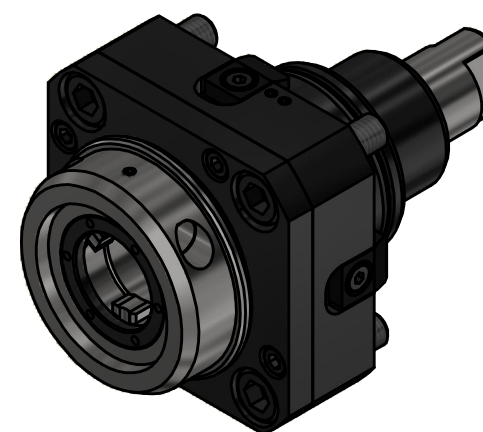

Copyright **EWS Tool Technologies**
Weitergabe und Vervielfaeltigung dieser Unterlage,
Verwertung und Mitteilung ihres Inhalts nicht
gestattet, soweit nicht ausdrucklich zugestanden.
Zuwaiderhandlungen verpflichten zu Schadenersatz.

Bemerkung - Note

Für Trockenlauf geeignet!
Use without coolant fluid allowed!

Technische Daten - technical data

Weight = 2.908 [kg]
Torque max. (M1/M2) = 50 / 50 [Nm]
Speed max. (n1/n2) = 6000 / 6000 [1/min]
Gear ratio (i)=n1:n2 = 1:1
Pressure (pmax) = 70 [bar]

Benennung - Title

Axial Bohr und Fräskopf
Axial drilling and milling head



Nr. - No.

40.55VX3VLHP2IKC

EWS Weigele GmbH & Co. KG
Maybachstr. 1
D-73066 Uhingen
www.ews-tools.de

Technische Aenderungen vorbehalten!
Subject to technical modifications!

IDENT: DEWS235646



REV: -/B

MNR.

227687

